



P-DUKE POWER

HAE150U Series

Half-Brick DC-DC Converter
Up to 150 Watts

3
YEARS
WARRANTY

ROHS
COMPLIANT

REACH
COMPLIANT

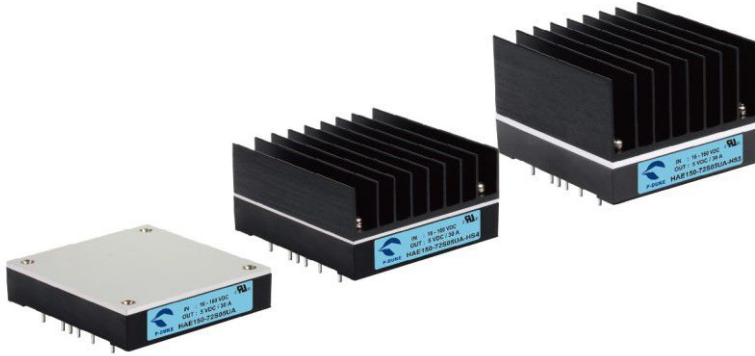

Railway



Automation



Datacom



IPC



Industry



Measurement



Telecom



Automobile



Boat



Charger



Medical



PV



3000 VAC
Reinforced
Insulation

10:1
Ultra-Wide
Input
Range

HOLD UP

NO
Min. Load
Required

Primary
PULSE
OUTPUT

REMOTE
ON
OFF

UVP
Adjustable

OCP

OTP

OVP

SCP

PART NUMBER STRUCTURE

HAE150 -	72	S	05	U	A	-	P	TH
Series Name	Input Voltage (VDC)	Output Quantity	Output Voltage (VDC)	Input Range	Pin Connection Options		Ctrl Logic Options	Assembly Options
	72:16~160 (Continuous) 12~185 (Transient) *Compliant with 24 to 110V battery systems of EN50155.	S:Single	05:5 12:12 15:15 24:24 28:28 48:48 53:53	10:1	A: A type (Standard) B: B type		□: Negative logic P: Positive logic	□: None Heat-sink type HS4:7GA0127P01-F; H=0.65" HS5:7GA0128P01-F; H=1" Through hole type TH: No thread* *The module can't equip Heat-sink with TH option.

TECHNICAL SPECIFICATION All specifications are typical at nominal input, full load and 25°C unless otherwise noted

Model Number	Input Range	Output Voltage	Output Current @Full Load	Input Current @No Load	Efficiency	Maximum Capacitor Load
	VDC	VDC	A	mA	%	µF
HAE150-72S05UA/B	16 ~ 160	5	30	35	91	45000
HAE150-72S12UA/B	16 ~ 160	12	12.5	20	93	8000
HAE150-72S15UA/B	16 ~ 160	15	10	25	92	5000
HAE150-72S24UA/B	16 ~ 160	24	6.3	20	89	2000
HAE150-72S28UA/B	16 ~ 160	28	5.4	15	89	1470
HAE150-72S48UA/B	16 ~ 160	48	3.2	20	93	470
HAE150-72S53UA/B	16 ~ 160	53	2.9	30	91	390

INPUT SPECIFICATIONS						
Parameter	Conditions			Min.	Typ.	Max. Unit
Operating input voltage range	72Vin(nom)	All		16	72	160 VDC
	Transient			12		185 VDC
	*Compliant with 24 to 110V battery systems of EN50155.					
Start up voltage	UVLO external resistor open ⁽¹⁾					16 VDC
Shutdown voltage	UVLO external resistor open ⁽¹⁾			10	11	12 VDC
Start up time	Constant resistive load	Power up	Remote ON/OFF		350	ms
					350	
Input Transient voltage	100 mS, max.			12		VDC
Input surge voltage	1 second, max.					185 VDC
Input filter	C type					
Remote ON/OFF	Referred to -Vin pin	Negative logic (Standard)	DC-DC ON			Short or 0 ~ 1.2VDC
			DC-DC OFF			Open or 3 ~ 12VDC
		Positive logic (Option)	DC-DC ON			Open or 3 ~ 12VDC
			DC-DC OFF			Short or 0 ~ 1.2VDC
		Input current of Ctrl pin		-0.5	1	mA
		Remote off input current			15	mA

OUTPUT SPECIFICATIONS						
Parameter	Conditions			Min.	Typ.	Max. Unit
Voltage accuracy				-1.0		+1.0 %
Line regulation	Low Line to High Line at Full Load			-0.2		+0.2 %
Load regulation	No Load to Full Load			-0.1		+0.1 %
Voltage adjustability	Single output			-20		+10 %
Remote sense	% of Vout(nom).					10 %
	If remote sense is not being used, SENSE pins should connect to corresponding polarity Vout pins.					
Ripple and noise	Measured by 20MHz bandwidth					mVp-p
		With a 22µF/25V X7R MLCC and a 22µF/25V POS-CAP	5Vout		75	
		With a 22µF/25V X7R MLCC and a 22µF/25V POS-CAP	12Vout, 15Vout		150	
		With a 2.2µF/50V X7R MLCC	24Vout, 28Vout		200	
		With a 1µF/100V X7R MLCC	48Vout, 53Vout		300	
Temperature coefficient				-0.02		+0.02 %/°C
Transient response recovery time	25% load step change				250	µs
Over voltage protection	% of Vout(nom); Hiccup mode			115		130 %
Over load protection	% of Iout rated; Hiccup mode			120		150 %
Short circuit protection				Continuous, automatics recovery		

GENERAL SPECIFICATIONS

Parameter	Conditions	Min.	Typ.	Max.	Unit
Isolation voltage	1 minute(Reinforced insulation) Input to Output Input (Output) to Base-Plate	3000 1500			VAC
Isolation resistance	500VDC	1			GΩ
Isolation capacitance			1000		pF
Switching frequency		189	210	231	kHz
Safety approvals	IEC/ EN/ UL62368-1				UL:E193009 CB:UL(Demko)
Standard approvals	EN50155 EN45545-2				
Case material		Aluminum base-plate with plastic case			
Potting material		Silicone (UL94 V-0)			
Weight		113g (3.99oz)			
MTBF	MIL-HDBK-217F, Full load	3.093 x 10 ⁵ hrs			

ENVIRONMENTAL SPECIFICATIONS

Parameter	Conditions	Min.	Typ.	Max.	Unit
Operating base-plate temperature	With derating	-40		+105	°C
Maximum case temperature				105	°C
Over temperature protection			115		°C
Storage temperature range		-55		+125	°C
Thermal impedance	Module without assembly options Only mount on the aluminum base-plate Heat-sink type with 0.65" Height Heat-sink type with 1" Height		6.1 2.0 4.6 3.7		°C/W
Thermal shock					MIL-STD-810F
Shock					EN61373, MIL-STD-810F
Vibration					EN61373, MIL-STD-810F
Relative humidity					5% to 95% RH

EMC SPECIFICATIONS

Parameter	Conditions	Level
EMI	EN55032, EN50121-3-2 With external components	Class A, Class B
EMS	EN55035, EN50121-3-2	
ESD	EN61000-4-2 Air ± 8kV and Contact ± 6kV	Perf. Criteria A
Radiated immunity	EN61000-4-3 20 V/m	Perf. Criteria A
Fast transient	EN61000-4-4 ± 2kV	Perf. Criteria A
Surge	EN61000-4-5 With external components ±2kV	Perf. Criteria A
Conducted immunity	EN61000-4-6 With external components 10 Vr.m.s	Perf. Criteria A
Power frequency magnetic field	EN61000-4-8 100A/m continuous; 1000A/m 1 second	Perf. Criteria A

Note:

1. Refer to "TYPICAL APPLICATION" for detailed information about UVLO.

CAUTION:

1. This power module is not internally fused. An input line fuse must always be used.
2. The BUS pin is designed for enhanced hold-up function. It is not recommended to apply in different applications.
3. A Cbus must always be used. Please refer to "Cbus" section.

CHARACTERISTIC CURVE

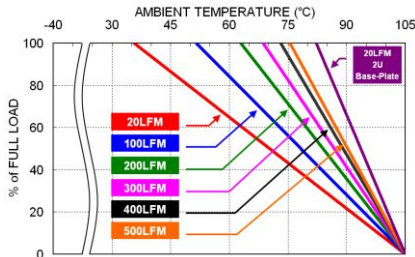

HAE150-72S12UA Derating Curve
(See Thermal Considerations)

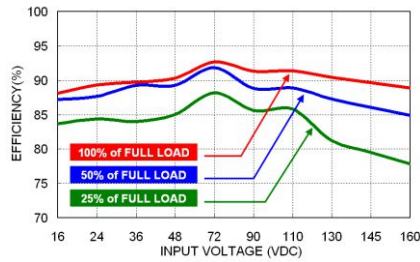

HAE150-72S12UA Efficiency vs. Input Voltage

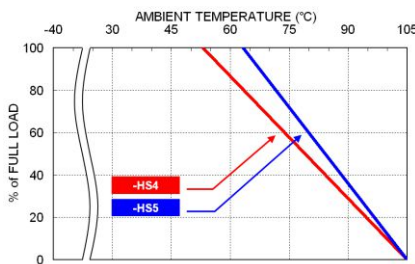

HAE150-72S12UA Derating Curve with Heat-sink
(See Thermal Considerations)

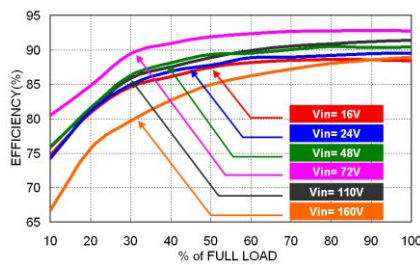

HAE150-72S12UA Efficiency vs. Output Load

FUSE CONSIDERATION

This power module is not internally fused. An input line fuse must always be used.

This encapsulated power module can be used in a wide variety of applications, ranging from simple stand-alone operation to an integrated part of sophisticated power architecture.

To maximum flexibility, internal fusing is not included; however, to achieve maximum safety and system protection, always use an input line fuse.

The input line fuse suggest as below :

Location	Fuse Rating (A)	Fuse Type
Input Line	15	Fast-Acting
BUS Line (Option)	5	Fast-Acting

The table based on the information provided in this data sheet on inrush energy and maximum DC input current at low Vin.

MECHANICAL DRAWING

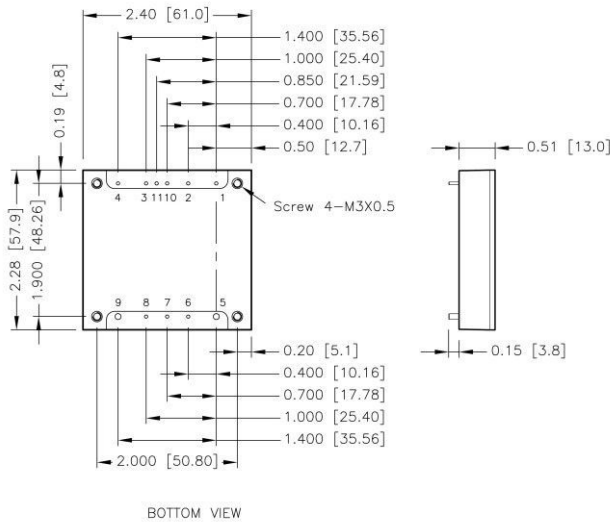

BOTTOM VIEW

■ The screw locked torque: MAX 3.5kgf-cm/0.34N-m

PIN CONNECTION

PIN	A-TYPE	B-TYPE	DIAMETER
1	-Vin	-Vin	0.04 Inch
2	BUS	BUS	0.04 Inch
3*	Ctrl	UVLO	0.04 Inch
4	+Vin	+Vin	0.04 Inch
5	-Vout	-Vout	0.08 Inch
6	-Sense	-Sense	0.04 Inch
7	Trim	Trim	0.04 Inch
8	+Sense	+Sense	0.04 Inch
9	+Vout	+Vout	0.08 Inch
10*	UVLO	Ctrl	0.04 Inch
11	Pulse Out	Pulse Out	0.04 Inch

* Differences between A-TYPE & B-TYPE.

- All dimensions in inch [mm]
- Tolerance :x.xxx±0.02 [x.xx±0.5]
x.xxx±0.010 [x.xx±0.25]
- Pin dimension tolerance ±0.004 [0.10]

RECOMMENDED PAD LAYOUT

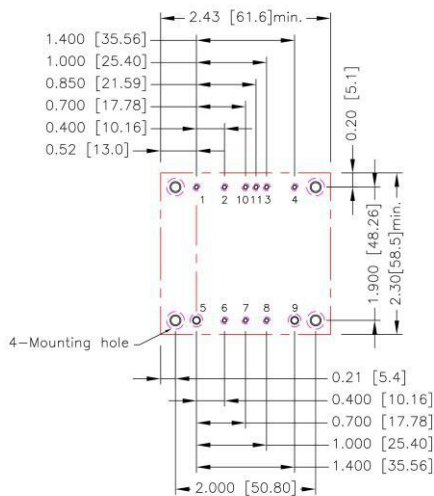

All dimensions in inch[mm]
 Pad size(lead free recommended)
 Through hole 1.2.3.4.6.7.8.10.11:Φ0.051[1.30]
 Through hole 5.9:Φ0.091[2.30]
 Through hole of mounting:Φ0.126[3.20]
 Top view pad 1.2.3.4.6.7.8.10.11:Φ0.064[1.63]
 Top view pad 5.9:Φ0.113[2.88]
 Top view pad of mounting:Φ0.157[4.00]
 Bottom view pad 1.2.3.4.6.7.8.10.11:Φ0.102[2.60]
 Bottom view pad 5.9:Φ0.181[4.60]
 Bottom view pad of mounting:Φ0.252[6.40]

THERMAL CONSIDERATIONS

The power module operates in a variety of thermal environments.

However, sufficient cooling should be provided to help ensure reliable operation of the unit.

Heat is removed by conduction, convection, and radiation to the surrounding environment.

Proper cooling can be verified by measuring the point as the figure below.

The temperature at this location should not exceed "Maximum case temperature".

When operating, adequate cooling must be provided to maintain the test point temperature at or below "Maximum case temperature".

You can limit this temperature to a lower value for extremely high reliability.

- Thermal test condition with vertical direction by natural convection (20LFM).
- The aluminum base-plate dimension is 19" X 3.5" X 0.063" (The height is EIA standard 2U).
- The Heat-sink is optional and P/N: 7GA0127P01-F, 7GA0128P01-F.

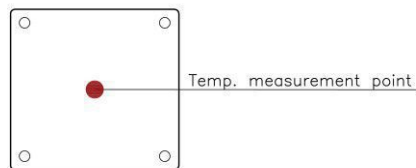

BASE PLATE

HEAT-SINK TYPE OPTIONS

HAE150-□□S□□UA/B -**HS4**
7GA0127P01-F

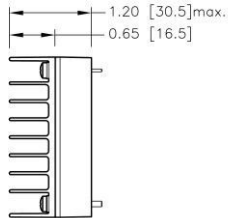
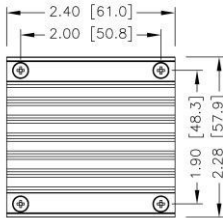

SIDE VIEW

HAE150-□□S□□UA/B -**HS5**
7GA0128P01-F

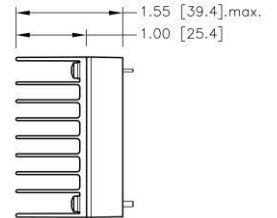
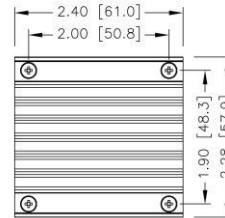

SIDE VIEW

1. All dimensions in inch [mm]
2. Tolerance :x.xx±0.02 [x.x±0.5]
x.xxx±0.01 [x.xx±0.25]

TYPICAL APPLICATION

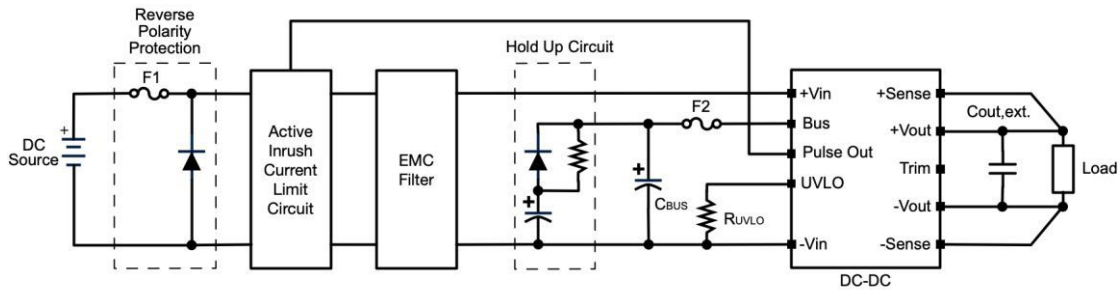

Typical Connection

C_{BUS}

An 150µF Electrolytic Cap should always be installed and connected to the BUS pin for module's stability.

*F2 is not necessarily needed. The fuse, F2, can protect the dc/dc module from damage caused by short-circuiting of peripheral components connected to the BUS pin.

C _{BUS}	150µF / 200V , Nippon Chemi-con KXJ series
F2	5A Fast-Acting , Littelfuse

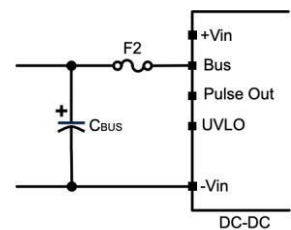

C_{BUS} Connection

UVLO

UVLO pin provides the function of programmable input turn on/ off voltage by connecting a resistor between UVLO and -Vin. The following equations are used for calculating the value of input voltage and R_{UVLO}. Or can simply reference the table shown as below to obtain the suitable R_{UVLO} value to the system.

$$V_{in, ON} = \frac{451.23}{R_{UVLO} + 3} + 13.26 \quad (V)$$

$$V_{in, OFF} = \frac{448.5}{R_{UVLO} + 3} + 11.00 \quad (V)$$

System Voltage, Un (V)	24	36	48	72	96	110
Start-up Voltage (V)	13.3	21.6	28.8	43.2	57.6	66.0
Shutdown Voltage (V)	11.0	19.3	26.4	40.8	55.1	63.4
R _{UVLO} (kΩ)	Open	51.12	26.04	12.07	7.18	5.56

Reference table for R_{UVLO}

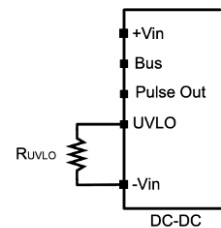

R_{UVLO} Connection

Pulse Out

The Pulse out pin can provide 12V, 1kHz, 50% duty square wave signal. It provides the function that could achieve inrush current limit with external circuit. If Pulse Out pin is not to be used, please left this pin floating.

When Pulse Out pin is high level, the source current of pulse out pin should be limited no more than 10mA. For resistive load, higher than 1.2kΩ is necessary.

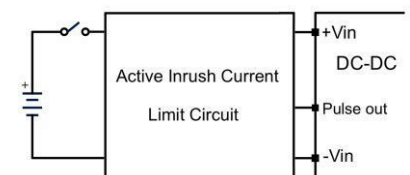

Pulse Out Connection

For further information of "Enhanced Hold-up, Reverse Polarity Protection, Active Inrush Current Limit Circuit, and EMC Filter", please contact P-DUKE.

OUTPUT VOLTAGE ADJUSTMENT

Output voltage is adjustable for 10% trim up or -20% trim down of nominal output voltage by connecting an external resistor between the Trim pin and either the +Sense or -Sense pins.

With an external resistor between the Trim and -Sense pin, the output voltage set point decreases.

With an external resistor between the Trim and +Sense pin, the output voltage set point increases.

Maximum output deviation is +10% inclusive of remote sense.

The external Trim resistor needs to be at least 1/8W of rated power.

Trim Up Equation

$$R_U = \left(\frac{V_{OUT}(100 + \Delta\%) - 100 + 2\Delta\%}{1.225\Delta\%} - \frac{100 + 2\Delta\%}{\Delta\%} \right) k\Omega$$

Trim Down Equation

$$R_D = \left(\frac{100}{\Delta\%} - 2 \right) k\Omega$$

EXTERNAL OUTPUT TRIMMING

Output can be externally trimmed by using the method shown below.

Trim-up

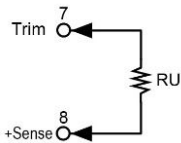

72S05UA/B

ΔV (%)	1	2	3	4	5	6	7	8	9	10
Vout (V)	5.05	5.10	5.15	5.20	5.25	5.30	5.35	5.40	5.45	5.50
R _U (k Ω)	310.245	156.163	104.803	79.122	63.714	53.442	46.105	40.602	36.322	32.898

72S12UA/B

ΔV (%)	1	2	3	4	5	6	7	8	9	10
Vout (V)	12.12	12.24	12.36	12.48	12.60	12.72	12.84	12.96	13.08	13.20
R _U (k Ω)	887.388	447.592	300.993	227.694	183.714	154.395	133.452	117.745	105.528	95.755

72S15UA/B

ΔV (%)	1	2	3	4	5	6	7	8	9	10
Vout (V)	15.15	15.30	15.45	15.60	15.75	15.90	16.05	16.20	16.35	16.50
R _U (k Ω)	1134.735	572.490	385.075	291.367	235.143	197.660	170.886	150.806	135.188	122.694

72S24UA/B

ΔV (%)	1	2	3	4	5	6	7	8	9	10
Vout (V)	24.24	24.48	24.72	24.96	25.20	25.44	25.68	25.92	26.16	26.40
R _U (k Ω)	1876.776	947.184	637.320	482.388	389.429	327.456	283.190	249.990	224.168	203.510

72S28UA/B

ΔV (%)	1	2	3	4	5	6	7	8	9	10
Vout (V)	28.28	28.56	28.84	29.12	29.40	29.68	29.96	30.24	30.52	30.80
R _U (k Ω)	2206.571	1113.714	749.429	567.286	458.000	385.143	333.102	294.071	263.714	239.429

72S48UA/B

ΔV (%)	1	2	3	4	5	6	7	8	9	10
Vout (V)	48.48	48.96	49.44	49.92	50.40	50.88	51.36	51.84	52.32	52.80
R _U (k Ω)	3855.551	1946.367	1309.973	991.776	800.857	673.578	582.665	514.480	461.447	419.020

72S53UA/B

ΔV (%)	1	2	3	4	5	6	7	8	9	10
Vout (V)	53.53	54.06	54.59	55.12	55.65	56.18	56.71	57.24	57.77	58.30
R _U (k Ω)	4267.769	2154.531	1450.109	1097.898	886.571	745.6871	645.055	569.582	510.880	463.918

OUTPUT VOLTAGE ADJUSTMENT (CONTINUED)

Trim-down

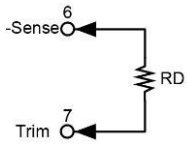

72S□□UA/B

ΔV (%)	1	2	3	4	5	6	7	8	9	10
RD (k Ω)	98.000	48.000	31.333	23.000	18.000	14.667	12.286	10.500	9.111	8.000
ΔV (%)	11	12	13	14	15	16	17	18	19	20
RD (k Ω)	7.091	6.333	5.692	5.143	4.667	4.250	3.882	3.556	3.263	3.000