



P-DUKE POWER

MAD180 Series

2 X 3 Inch AC-DC POWER SUPPLIES
Up to 180 Watts

5
YEARS
WARRANTY

ROHS
COMPLIANT

REACH
COMPLIANT

+85°C
-40°C
AMBIENT TEMP.



Medical



Automation



Datacom



IPC



Industry



Measurement



Telecom



Automobile



Boat



Charger



PV



Railway

UL US CB CE UK CA



- 2
x
MOPP
- 4000
VAC
Reinforced
Insulation
- ADJ.
Output
Voltage
- Internal
EN55032
Class
Filter **B**
- LOW
Leakage
Current
- LOW
Standby
Power
- Operating
Altitude
5000
meter
- Protection
Class I
Class II
- OCP**
- OVP**
- SCP**
- OTP**

PART NUMBER STRUCTURE

MAD180	U	S	12	A	-	M	
Series Name	Universal Input (VAC)	Output Quantity	Output Voltage (VDC)	Protection Type			Package Options
	85-264	Single	12:12V 15:15V 18:18V 24:24V 28:28V 36:36V 48:48V 53:53V	A: CLASS I B: CLASS II			<input type="checkbox"/> : Open type E1 : Enclosed type D1 : Din rail type

TECHNICAL SPECIFICATION All specifications are typical at 230VAC input, full load and 25°C unless otherwise noted

Model Number	Input Range	Output Voltage	Output Current		Input Power @ No Load	Efficiency	Maximum Capacitor Load
			Natural Convection	Forced Air Cooling With 10 CFM			
	VAC	VDC	A	A	W	%	μF
MAD180US12A-M	85 ~ 264	12	12.5	15	0.15	92	10000
MAD180US15A-M	85 ~ 264	15	10	12	0.15	92	6800
MAD180US18A-M	85 ~ 264	18	8.34	10	0.15	92	4700
MAD180US24A-M	85 ~ 264	24	6.25	7.5	0.15	94	2700
MAD180US28A-M	85 ~ 264	28	5.36	6.43	0.15	93	1800
MAD180US36A-M	85 ~ 264	36	4.17	5	0.15	93	1200
MAD180US48A-M	85 ~ 264	48	3.13	3.75	0.15	93	680
MAD180US53A-M	85 ~ 264	53	2.83	3.40	0.15	93	560

INPUT SPECIFICATIONS

Parameter	Conditions	Min.	Typ.	Max.	Unit
Operating input voltage range	AC input	85		264	VAC
	DC input	120		370	VDC
Input frequency	AC input	47		63	Hz
Input current	100VAC and Full Load			3	A
	240VAC and Full Load			1.5	A
No load input power	230VAC		0.15		Watts
Leakage current	264VAC			100	μA
Power factor		0.95			
Start up time				1500	ms
Rise time			15		ms
Hold up time	115VAC and 150W	10			ms
Input inrush current	230VAC			100	A
Input protection	Internal fuse			T4.0A/250VAC	

OUTPUT SPECIFICATIONS

Parameter	Conditions	Min.	Typ.	Max.	Unit
Output power	Forced air cooling with 10CFM			180	Watts
	Natural convection			150	Watts
Output peak power	Peak power			220	Watts
	Peak power time		5		s
	Peak power duty		20		%
	Average operation power (% of Full Load)		55		%
Initial set voltage accuracy	230VAC and Full Load	-1.0		+1.0	%
Line regulation	Low Line to High Line at Full Load	-0.2		+0.2	%
Load regulation	No Load to Full Load	-0.5		+0.5	%
	10% Load to 90% Load	-0.4		+0.4	%
Voltage adjustability		-8		+8	%
Minimum load			0		%
Ripple and noise	Measured by 20MHz bandwidth				
	With a 1μF/25V 1206 X7R MLCC		120		mVp
	With a 1μF/50V 1206 X7R MLCC		120		mVp
	With a 0.1μF/100V 1206 X7R MLCC		250		mVp
Temperature coefficient		-0.02		+0.02	%/°C
Transient response	Load step from 100 ~ 75% change at 2.5A/μs	Peak deviation	3		% Vout
		Recovery time	600		μs
Over voltage protection	% of Vout(nom); Latch mode	115		135	%
Over load protection	% of Iout rated; Hiccup mode		150		%
Short circuit protection					Continuous, automatic recovery

GENERAL SPECIFICATIONS

Parameter	Conditions	Min.	Typ.	Max.	Unit
Isolation voltage	1 minute (2MOPP insulation) Input to Output Input (Output) to F.G.	4000 2500			VAC
Isolation resistance	500VDC	0.1			GΩ
Switching frequency	230VAC, Full load		170		kHz
Safety approvals	IEC/ EN/ ANSI/AAMI ES 60601-1 IEC/ EN/ UL 62368-1			UL:E360199 UL:E193009 CB:UL(Demko)	
Weight	Open type Enclosed type Din rail type			162g (5.70oz) 218g (7.70oz) 240g (8.47oz)	
MTBF	MIL-HDBK-217F Ta=25°C, Full load			1.145 x 10 ⁶	hrs

ENVIRONMENTAL SPECIFICATIONS

Parameter	Conditions	Min.	Typ.	Max.	Unit
Operating ambient temperature	With derating	-40		+85	°C
Storage temperature range		-40		+85	°C
Over temperature protection	Internal thermistor; Hiccup mode		125		°C
Operating altitude				5000	m
Thermal shock				MIL-STD-810F	
Shock				IEC60068-2-27	
Vibration				IEC60068-2-6	
Relative humidity	Non-condensing			5% to 95%	RH

EMC SPECIFICATIONS

Parameter	Conditions	Level
EMI	EN55011, EN55032, EN60601-1-2, and FCC Part 18 / 15	Conducted Radiated Class B Class A
Harmonic currents	EN61000-3-2 Full Load	ClassD
Voltage flicker	EN61000-3-3	
EMS	EN55035 and EN60601-1-2	
ESD	EN61000-4-2	Perf. Criteria A
Radiated immunity	EN61000-4-3 20 V/m	Perf. Criteria A
Fast transient	EN61000-4-4 ± 2kV	Perf. Criteria A
Surge	EN61000-4-5 DM ± 1kV and CM ± 2kV	Perf. Criteria A
Conducted immunity	EN61000-4-6 20 Vr.m.s	Perf. Criteria A
Power frequency magnetic field	EN61000-4-8 30 A/m	Perf. Criteria A
Dip and interruptions	EN61000-4-11	

CHARACTERISTIC CURVE

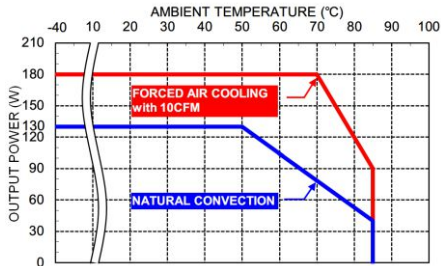

Derating Curve vs. Ambient Temperature
Vin=115VAC Open type

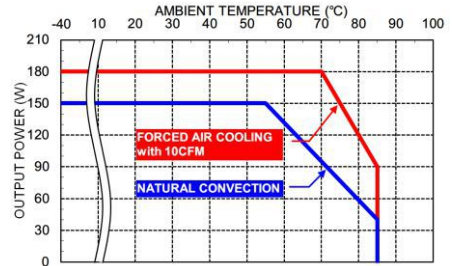

Derating Curve vs. Ambient Temperature
Vin=230VAC Open type

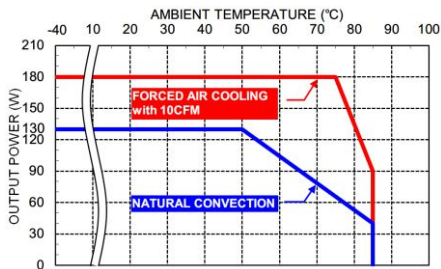

Derating Curve vs. Ambient Temperature
Vin=115VAC Enclosed type / Din rail type

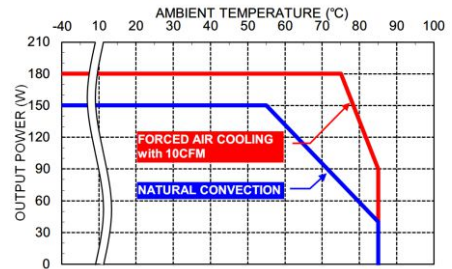

Derating Curve vs. Ambient Temperature
Vin=230VAC Enclosed type / Din rail type

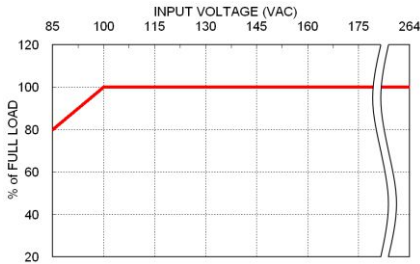

Derating Curve vs. Input Voltage
MAD180

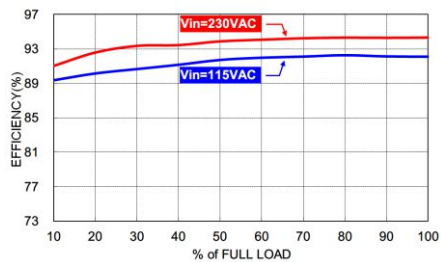

Efficiency vs. Output Load
MAD180US24 with Forced air cooling

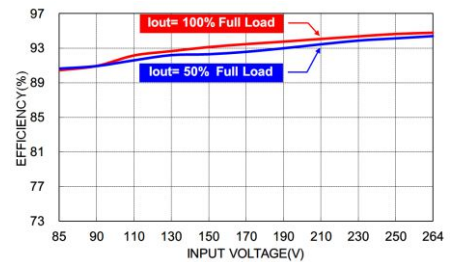

Efficiency vs. Input Voltage
MAD180US24 with Forced air cooling

MECHANICAL DRAWING

Open type

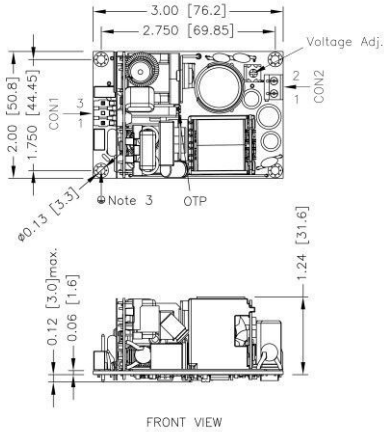

CONNECTORS CONNECTIONS

CON1 – Input Connector

Pin 3	Line
Pin 1	Neutral

Mates with
Molex housing : **09-93-0300, 09-50-3031, 09-50-8031**
Molex crimp terminals : **2478**

CON2 – Output Connector

Pin 1	+Vout
Pin 2	-Vout

Mates with
Screw locked torque **MAX 2.5Kgf.cm/0.25N.m**
Wire dimension range **24 ~ 14AWG**

1. All dimensions in inch [mm]

Tolerance : $x.xx \pm 0.02$ [$x.x \pm 0.5$]

$x.xxx \pm 0.01$ [$x.xx \pm 0.25$]

2. The CON2 locked torque: **MAX 2.5Kgf.cm/0.25N.m**

3. The screws holes can be considered as PE connection for CLASS I application.

MECHANICAL DRAWING

Enclosed type

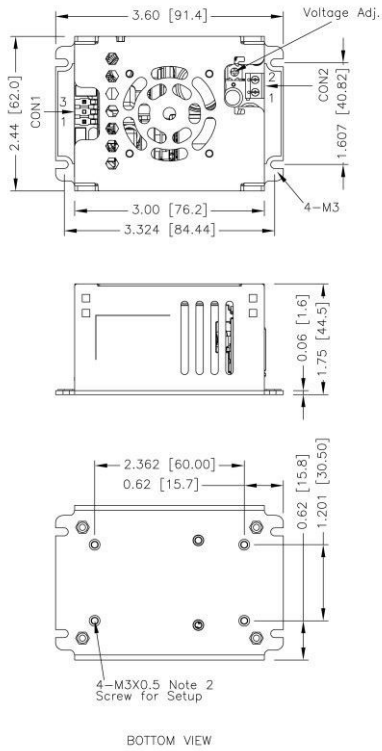

Din rail type

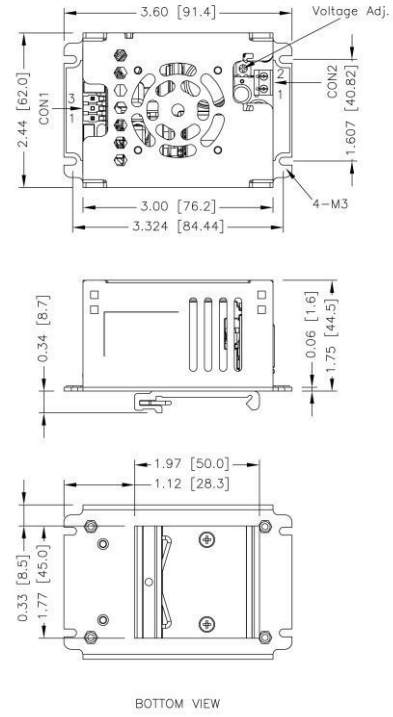

- All dimensions in inch [mm]
Tolerance : x.xx±0.02 [x.x±0.5]
x.xxx±0.01 [x.xx±0.25]
- The screw locked torque: MAX 5Kgf.cm/0.49N.m
- The CON2 locked torque: MAX 2.5Kgf.cm/0.25N.m

- All dimensions in inch [mm]
Tolerance : x.xx±0.02 [x.x±0.5]
x.xxx±0.01 [x.xx±0.25]
- The CON2 locked torque: MAX 2.5Kgf.cm/0.25N.m

CONNECTORS CONNECTIONS

CON1 – Input Connector

Pin 3	Line
Pin 1	Neutral

Mates with
Molex housing : **09-93-0300, 09-50-3031, 09-50-8031**
Molex crimp terminals : **2478**

CON2 – Output Connector

Pin 1	+Vout
Pin 2	-Vout

Mates with
Screw locked torque MAX 2.5Kgf.cm/0.25N.m
Wire dimension range 24 ~ 14AWG