

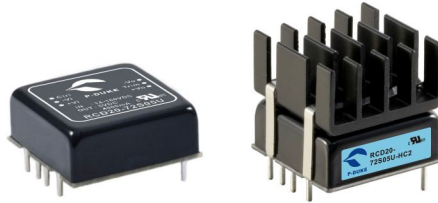

3
YEARS
WARRANTY

ROHS
COMPLIANT

REACH
COMPLIANT



Railway



Automation



Datacom



IPC



Industry



Measurement



Telecom



Automobile



Boat



Charger



Medical



PV



3000
VDC
Isolation
Voltage

12:1
Ultra-Wide
Input
Range

6
sided
Shielding

HOLD
UP

LOW
Standby
Power

NO
Min. Load
Required

REMOTE
ON
OFF

UVP
Adjustable

OCP

OVP

SCP

UVP

OTP

PART NUMBER STRUCTURE

Series Name	Input Voltage (VDC)	Output Quantity	Output Voltage (VDC)	Input Range	Remote ON/OFF & Trim Options	Bus & UVP adj. Options	Assembly Options
RCD20 - 72 S 05 U - A K HC1	36: 9~75 72: 14~160	S: Single D: Dual	05: 5 5P1: 5.1 12: 12 15: 15 24: 24 12: ±12 15: ±15	8:1 12:1	<input type="checkbox"/> : Negative logic A: Positive logic	<input type="checkbox"/> : None K: With Bus. V: With UVP adj.	<input type="checkbox"/> : None HC1: 7GA0117P01-F ;H=0.3" HC2: 7GA0118P01-F ;H=0.5" HC3: 7GA0119P01-F ;H=0.8"

TECHNICAL SPECIFICATION All specifications are typical at nominal input, full load and 25°C unless otherwise noted

Model Number	Input Range	Output Voltage	Output Current @Full Load	Input Current @No Load	Efficiency	Maximum Capacitor Load
	VDC	VDC	mA	mA	%	μF
RCD20-36S05U	9 ~ 75	5	4000	15	87	5000
RCD20-36S5P1U	9 ~ 75	5.1	4000	15	87	5000
RCD20-36S12U	9 ~ 75	12	1670	12	88	850
RCD20-36S15U	9 ~ 75	15	1330	12	88	700
RCD20-36S24U	9 ~ 75	24	835	12	88	220
RCD20-36D12U	9 ~ 75	±12	±833	12	88	±500
RCD20-36D15U	9 ~ 75	±15	±667	12	88	±350
RCD20-72S05U	14 ~ 160	5	4000	8	87	5000
RCD20-72S5P1U	14 ~ 160	5.1	4000	8	87	5000
RCD20-72S12U	14 ~ 160	12	1670	8	88	850
RCD20-72S15U	14 ~ 160	15	1330	8	88	700
RCD20-72S24U	14 ~ 160	24	835	8	88	220
RCD20-72D12U	14 ~ 160	±12	±833	8	88	±500
RCD20-72D15U	14 ~ 160	±15	±667	8	88	±350

INPUT SPECIFICATIONS						
Parameter	Conditions		Min.	Typ.	Max.	Unit
Operating input voltage range	36Vin(nom)		9	36	75	VDC
	72Vin(nom)		14	72	160	
Start up voltage	36Vin(nom)					VDC
	72Vin(nom)		9			
Shutdown voltage	36Vin(nom)		7.3	7.7	8.1	VDC
	72Vin(nom)		10	11	12	
Start up time	Constant resistive load	Power up	30		40	ms
		Remote ON/OFF	30		40	
Input Transient voltage	1 second, max.	36Vin(nom)	8.1			VDC
		72Vin(nom)	12			
Input surge voltage	1 second, max.	36Vin(nom)				VDC
		72Vin(nom)	100			
Input filter		Pi type				
Remote ON/OFF	Referred to -Vin pin	Positive logic	Open or 3 ~ 15VDC			mA
		(Option) DC-DC ON	Short or 0 ~ 1.2VDC			
		Negative logic	Open or 3 ~ 15VDC			mA
		(Standard) DC-DC ON	Short or 0 ~ 1.2VDC			
		Input current of Ctrl pin	-0.5	+1.0		
		Remote off input current	2.5			

OUTPUT SPECIFICATIONS						
Parameter	Conditions		Min.	Typ.	Max.	Unit
Voltage accuracy			-1.0		+1.0	%
Line regulation	Low Line to High Line at Full Load	Single	-0.2		+0.2	%
		Dual	-0.5		+0.5	
Load regulation	No Load to Full Load	Single	-0.2		+0.2	%
		Dual	-1.0		+1.0	
	10% Load to 90% Load	Single	-0.1		+0.1	
		Dual	-0.8		+0.8	
Cross regulation	Asymmetrical load 25%/100% FL	Dual	-5.0		+5.0	%
Voltage adjustability	Single output	12Vout	-10		+10	%
		Others	-10		+20	
Ripple and noise	Measured by 20MHz bandwidth					
		Single		75		mVp-p
	With a 22µF/25V X7R MLCC	5Vout, 5.1Vout		100		
	With a 22µF/25V X7R MLCC	12Vout, 15Vout		125		
	With a 4.7µF/50V X7R MLCC	24Vout				
With a 10µF/25V X7R MLCC for each output	Dual 12Vout, 15Vout		100			
Temperature coefficient			-0.02		+0.02	%/°C
Transient response recovery time	25% load step change			250		µs
Over voltage protection			6.3		7.4	VDC
			13.5		19.6	
			18.3		22.0	
			29.1		32.5	
Over load protection	% of lout rated; Hiccup mode			155		%
Short circuit protection						Continuous, automatics recovery

GENERAL SPECIFICATIONS						
Parameter	Conditions		Min.	Typ.	Max.	Unit
Isolation voltage	1 minute	Input to Output	3000			VDC
		Input (Output) to Case	2250			
Isolation resistance	500VDC		1			GΩ
Isolation capacitance					2000	pF
Switching frequency			190	220	250	KHz
Safety approvals	IEC/ EN/ UL 62368-1				UL:E193009 CB:UL(Demko)	
Standard approvals	EN50155 EN45545-2					
Case material						Copper
Base material						FR4 PCB
Potting material						Silicone (UL94 V-0)
Weight						17g (0.6oz)
MTBF	MIL-HDBK-217F, Full load					1.208 x 10 ⁶ hrs

ENVIRONMENTAL SPECIFICATIONS						
Parameter	Conditions		Min.	Typ.	Max.	Unit
Operating ambient temperature	With derating		-40		+105	°C
Maximum case temperature					105	°C
Over temperature protection				115		°C
Storage temperature range			-55		+125	°C
Thermal impedance	Natural convection	Without Heat-sink		14.3		°C/W
		With Heat-sink	HC1	11.5		
			HC2	10		
			HC3	8.5		
Thermal shock						MIL-STD-810F
Shock						EN61373, MIL-STD-810F
Vibration						EN61373, MIL-STD-810F
Relative humidity						5% to 95% RH

EMC SPECIFICATIONS		
Parameter	Conditions	Level
EMI	EN55032, EN50121-3-2 With external components	Class A, Class B
EMS	EN55035, EN50121-3-2	
ESD	EN61000-4-2 Air $\pm 8kV$ and Contact $\pm 6kV$	Perf. Criteria A
Radiated immunity	EN61000-4-3 20 V/m	Perf. Criteria A
Fast transient	EN61000-4-4 $\pm 2kV$	Perf. Criteria A
	RCD20-36□□□U RCD20-72□□□U	With an aluminum electrolytic capacitor (Nippon chemi-con KY series, 220 μ F/100V) and a TVS (SMDJ120A, 120V, 3000Watt peak pulse power) in parallel. With an aluminum electrolytic capacitor (Nippon chemi-con KXJ series, 150 μ F/200V) and a TVS (SMBJ220A, 220V, 600Watt peak pulse power) in parallel.
Surge	EN61000-4-5 $\pm 2kV$	Perf. Criteria A
	RCD20-36□□□U RCD20-72□□□U	With an aluminum electrolytic capacitor (Nippon chemi-con KY series, 220 μ F/100V) and a TVS (SMDJ120A, 120V, 3000Watt peak pulse power) in parallel. With an aluminum electrolytic capacitor (Nippon chemi-con KXJ series, 150 μ F/200V) and a TVS (SMBJ220A, 220V, 600Watt peak pulse power) in parallel.
Conducted immunity	EN61000-4-6 10 Vr.m.s	Perf. Criteria A
Power frequency magnetic field	EN61000-4-8 100A/m continuous; 1000A/m 1 second	Perf. Criteria A

CAUTION: This power module is not internally fused. An input line fuse must always be used.

CHARACTERISTIC CURVE

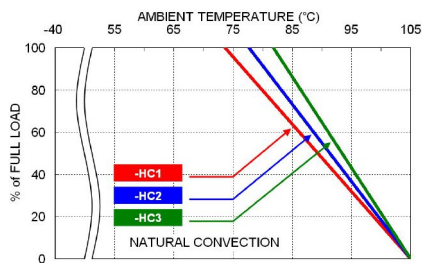
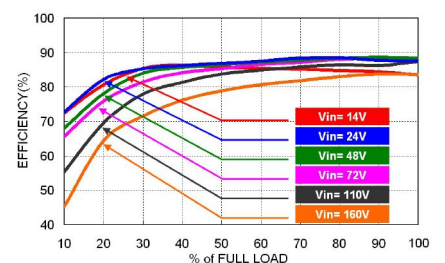
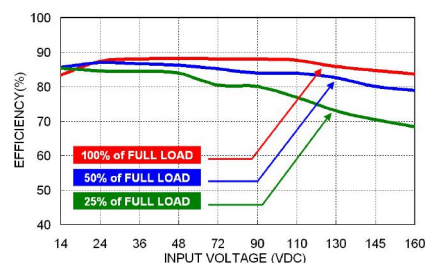
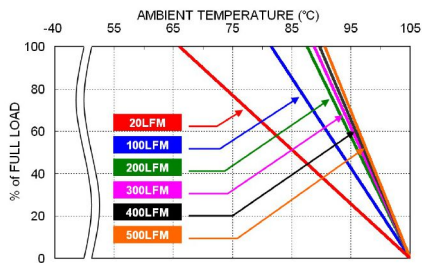

FUSE CONSIDERATION

This power module is not internally fused. An input line fuse must always be used.

This encapsulated power module can be used in a wide variety of applications, ranging from simple stand-alone operation to an integrated part of sophisticated power architecture.

To maximum flexibility, internal fusing is not included; however, to achieve maximum safety and system protection, always use an input line fuse.

The input line fuse suggest as below :

Modules	Fuse Rating (A)	Fuse Type
RCD20-36□□□U	4	Slow-Blow
RCD20-72□□□U	3.15	Slow-Blow

The table based on the information provided in this data sheet on inrush energy and maximum DC input current at low Vin..

MECHANICAL DRAWING

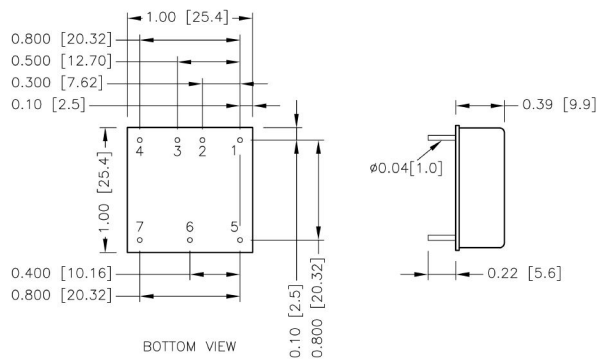

PIN CONNECTION

PIN	SINGLE	DUAL
1*	No Pin/ Bus/ UVP	No Pin/ Bus/ UVP
2	+Vin	+Vin
3	-Vin	-Vin
4	Ctrl	Ctrl
5	+Vout	+Vout
6	Trim	Common
7	-Vout	-Vout

- * The position of Pin 1 is tentative.
 Pin1 is "Bus" when choosing Bus option (-□K□)
 Pin1 is "UVP" when choosing UVP adj option (-□V□)

- All dimensions in inch [mm]
- Tolerance :x.xx±0.02 [x.x±0.5]
x.xxx±0.010 [x.xx±0.25]
- Pin dimension tolerance ±0.004[0.10]

RECOMMENDED PAD LAYOUT

Standard

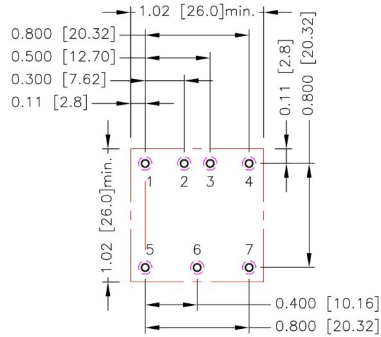

-HC1、-HC2、-HC3

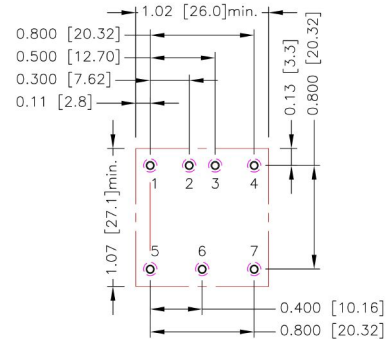

All dimensions in inch[mm]
 Pad size(lead free recommended)
 Through hole 1.2.3.4.5.6.7: $\Phi 0.051$ [1.30]
 Top view pad 1.2.3.4.5.6.7: $\Phi 0.064$ [1.63]
 Bottom view pad 1.2.3.4.5.6.7: $\Phi 0.102$ [2.60]

THERMAL CONSIDERATIONS

The power module operates in a variety of thermal environments.

However, sufficient cooling should be provided to help ensure reliable operation of the unit.

Heat is removed by conduction, convection, and radiation to the surrounding environment.

Proper cooling can be verified by measuring the point as the figure below.

The temperature at this location should not exceed "Maximum case temperature".

When operating, adequate cooling must be provided to maintain the test point temperature at or below "Maximum case temperature".

You can limit this temperature to a lower value for extremely high reliability.

- Thermal test condition with vertical direction by natural convection (20LFM).

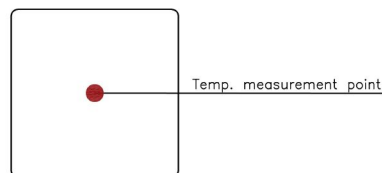

TOP VIEW

HEAT-SINK TYPE OPTIONS

RCD20-□□□□□U-**HC1**
7GA0117P01-F

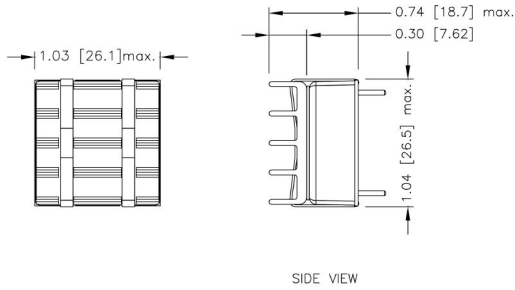

RCD20-□□□□□U-**HC2**
7GA0118P01-F

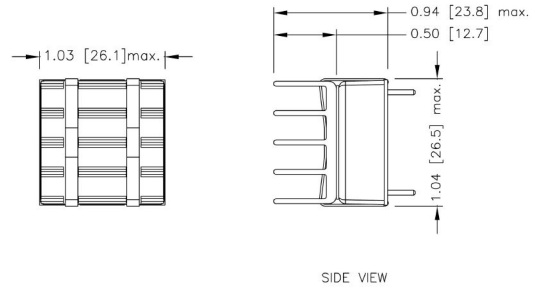

RCD20-□□□□□U-**HC3**
7GA0119P01-F

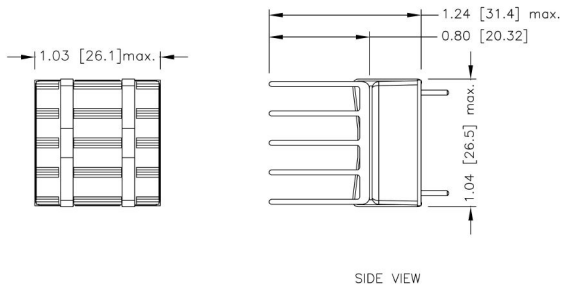

1. All dimensions in inch [mm]
2. Tolerance :x.xx±0.02 [x.x±0.5]
x.xxx±0.010 [x.xx±0.25]

TYPICAL APPLICATION

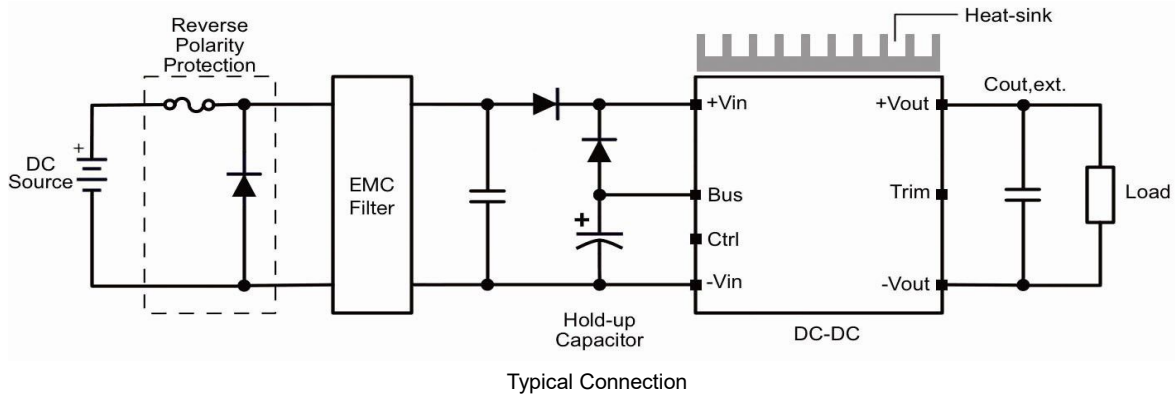

UVLO

This series product has ultra wide input range. It could cover many kind of nominal input voltage in one module. In order to preventing incorrect operating under different input system, it offers UVLO adjustment by connecting a resistor to set UVLO threshold.

UVLO Constants

Model	A	B	C
RCD20-36□□□U	14804	144000	16500
RCD20-72□□□U	22330	321000	24000

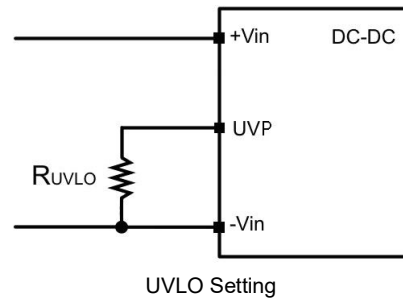

UVLO Equation

Start-up Voltage

$$V_{\text{start-up}} = \left(0.8 + \frac{A \times R_{\text{UVLO}}}{A + R_{\text{UVLO}}} \times 5 \times 10^{-6} \right) \times \left(1 + B \times \frac{C + R_{\text{UVLO}}}{C \times R_{\text{UVLO}}} \right)$$

Shutdown Voltage

$$V_{\text{shutdown}} = 0.785 \times \left(1 + B \times \frac{R_{\text{UVLO}} + C}{R_{\text{UVLO}} \times C} \right)$$

UVLO values for various nominal input voltage and R_{UVLO} table

RCD20-36□□□U

Nominal Vin	12 V	24 V	36 V	48 V
Start-up voltage	8.5 V	14.8 V	22.0 V	29.2 V
Shutdown voltage	7.6 V	13.8 V	20.9 V	28.0 V
UVLO Setting resistor	OPEN	18.3 KΩ	8.54 KΩ	5.57 KΩ

RCD20-72□□□U

Nominal Vin	24 V	36 V	48 V	72 V	96 V	110 V
Start-up voltage	14.8 V	22 V	29.2 V	43.6 V	58.0 V	66.4 V
Shutdown voltage	13.0 V	20.0V	27.1 V	41.2 V	55.3 V	63.6 V
UVLO Setting resistor	151.5 KΩ	28.87 KΩ	15.95 KΩ	8.42 KΩ	5.72 KΩ	4.82 KΩ

Hold Up Time

Generally, connecting a large number of hold up capacitors on input are necessary to get a long duration of hold up time for S2, C2 described in EN50155. The Bus pin features excellent function can simply connect capacitors to Bus pin with less quantity of capacitors. It helps reduce layout area and smooth the inrush current.

For further information, please contact P-DUKE.

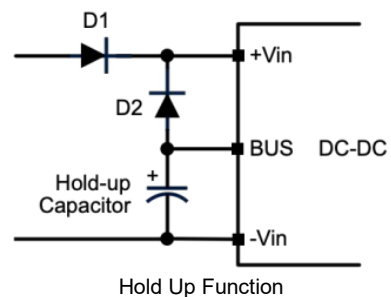

OUTPUT VOLTAGE ADJUSTMENT

Output voltage set point adjustment allows the user to increase or decrease the output voltage set point of the module. This is accomplished by connecting an external resistor between the Trim pin and either the +Output or -Output pins. With an external resistor between the Trim and -Output pin, the output voltage set point increases. With an external resistor between the Trim and +Output pin, the output voltage set point decreases. The external Trim resistor needs to be at least 1/16W of rated power.

Trim Up Equation

$$R_U = \left[\frac{G \times L}{(V_{o,up} - L - K)} - H \right] \Omega$$

Trim Down Equation

$$R_D = \left[\frac{(V_{o,down} - L) \times G}{(V_o - V_{o,down})} - H \right] \Omega$$

Trim Constants

Module	G	H	K	L
RCD20-□□S05U	5110	2050	2.5	2.5
RCD20-□□S5P1U	5110	2050	2.6	2.5
RCD20-□□S12U	10000	5110	9.5	2.5
RCD20-□□S15U	10000	5110	12.5	2.5
RCD20-□□S24U	56000	13000	21.5	2.5

EXTERNAL OUTPUT TRIMMING

Output can be externally trimmed by using the method shown below.

Trim-up

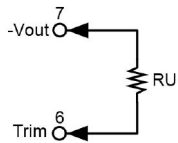

□□S05U

ΔV (%)	1	2	3	4	5	6	7	8	9	10
Vout (V)	5.050	5.100	5.150	5.200	5.250	5.300	5.350	5.400	5.450	5.500
R _U (kΩ)	253.450	125.700	83.117	61.825	49.050	40.533	34.450	29.888	26.339	23.500

ΔV (%)	11	12	13	14	15	16	17	18	19	20
Vout (V)	5.550	5.600	5.650	5.700	5.750	5.800	5.850	5.900	5.950	6.000
R _U (kΩ)	21.177	19.242	17.604	16.200	14.983	13.919	12.979	12.144	11.397	10.725

□□S5P1U

ΔV (%)	1	2	3	4	5	6	7	8	9	10
Vout (V)	5.151	5.202	5.253	5.304	5.355	5.406	5.457	5.508	5.559	5.610
R _U (kΩ)	248.440	123.195	81.447	60.573	48.048	39.698	33.734	29.261	25.782	22.999

ΔV (%)	11	12	13	14	15	16	17	18	19	20
Vout (V)	5.661	5.712	5.763	5.814	5.865	5.916	5.967	6.018	6.069	6.120
R _U (kΩ)	20.721	18.824	17.218	15.842	14.649	13.605	12.684	11.866	11.133	10.474

□□S12U

ΔV (%)	1	2	3	4	5	6	7	8	9	10
Vout (V)	12.120	12.240	12.360	12.480	12.600	12.720	12.840	12.960	13.080	13.200
R _U (kΩ)	203.223	99.057	64.334	46.973	36.557	29.612	24.652	20.932	18.038	15.723

□□S15U

ΔV (%)	1	2	3	4	5	6	7	8	9	10
Vout (V)	15.150	15.300	15.450	15.600	15.750	15.900	16.050	16.200	16.350	16.500
R _U (kΩ)	161.557	78.223	50.446	36.557	28.223	22.668	18.700	15.723	13.409	11.557

ΔV (%)	11	12	13	14	15	16	17	18	19	20
Vout (V)	16.650	16.800	16.950	17.100	17.250	17.400	17.550	17.700	17.850	18.000
R _U (kΩ)	10.042	8.779	7.711	6.795	6.001	5.307	4.694	4.149	3.662	3.223

□□S24U

ΔV (%)	1	2	3	4	5	6	7	8	9	10
Vout (V)	24.240	24.480	24.720	24.960	25.200	25.440	25.680	25.920	26.160	26.400
R _U (kΩ)	570.333	278.667	181.444	132.833	103.667	84.222	70.333	59.917	51.815	45.333

ΔV (%)	11	12	13	14	15	16	17	18	19	20
Vout (V)	26.640	26.880	27.120	27.360	27.600	27.840	28.080	28.320	28.560	28.800
R _U (kΩ)	40.030	35.611	31.872	28.667	25.889	23.458	21.314	19.407	17.702	16.167

OUTPUT VOLTAGE ADJUSTMENT(CONTINUED)

Trim-down

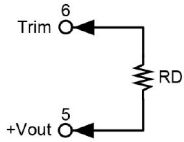

□□S05U

ΔV (%)	1	2	3	4	5	6	7	8	9	10
Vout (V)	4.950	4.900	4.850	4.800	4.750	4.700	4.650	4.600	4.550	4.500
RD (k Ω)	248.340	120.590	78.007	56.715	43.940	35.423	29.340	24.778	21.229	18.390

□□S5P1U

ΔV (%)	1	2	3	4	5	6	7	8	9	10
Vout (V)	5.049	4.998	4.947	4.869	4.845	4.794	4.743	4.692	4.641	4.590
RD (k Ω)	253.350	123.095	79.677	57.968	44.942	36.258	30.056	25.404	21.786	18.891

□□S12U

ΔV (%)	1	2	3	4	5	6	7	8	9	10
Vout (V)	11.880	11.760	11.640	11.520	11.400	11.280	11.160	11.040	10.920	10.800
RD (k Ω)	776.557	380.723	248.779	182.807	143.223	116.834	97.985	83.848	72.853	64.057

□□S15U

ΔV (%)	1	2	3	4	5	6	7	8	9	10
Vout (V)	14.850	14.700	14.550	14.400	14.250	14.100	13.950	13.800	13.650	13.500
RD (k Ω)	818.223	401.557	262.668	193.223	151.557	123.779	103.938	89.057	77.483	68.223

□□S24U

ΔV (%)	1	2	3	4	5	6	7	8	9	10
Vout (V)	23.760	23.520	23.280	23.040	22.800	22.560	22.320	22.080	21.840	21.600
RD (k Ω)	4947.667	2439.333	1603.222	1185.167	934.333	767.111	647.667	558.083	488.407	432.667