



P-DUKE POWER

RHD40W Series

DC-DC Converter
Up to 40 Watts

3
YEARS
WARRANTY

ROHS
COMPLIANT

REACH
COMPLIANT



Railway



Automation



Datacom



IPC



Industry



Measurement



Telecom



Automobile



Boat



Charger



Medical



PV

UL US CB CE UK CA

3000 VAC
Reinforced
Insulation

4 : 1
Wide
Input
Range

Internal
EN55032
Class
Filter **A**

LOW
Standby
Power

NO
Min. Load
Required

**REMOTE
ON
OFF**

OCP

OTP

OVP

SCP

UVP

PART NUMBER STRUCTURE

Series Name	Input Voltage (VDC)	Output Quantity	Output Voltage (VDC)	Input Range	Remote On/Off Options	Assembly Options
RHD40 -	110	S	05	W	-	N
	110:36~160	S:Single	05: 5 5P1: 5.1 12: 12 15: 15 24: 24	4:1	<input type="checkbox"/> :Positive logic <input type="checkbox"/> :Negative logic	<input type="checkbox"/> : None HS : 7G-0110A-F
		D: Dual	12: ±12 15: ±15			

TECHNICAL SPECIFICATION All specifications are typical at nominal input, full load and 25°C unless otherwise noted

Model Number	Input Range	Output Voltage	Output Current @Full Load	Input Current @No Load	Efficiency	Maximum Capacitor Load
	VDC	VDC	A	mA	%	μF
RHD40-110S05W	36 ~ 160	5	8	10	88	9600
RHD40-110S5P1W	36 ~ 160	5.1	8	10	88	9600
RHD40-110S12W	36 ~ 160	12	3.333	10	89	1667
RHD40-110S15W	36 ~ 160	15	2.666	10	90	1066
RHD40-110S24W	36 ~ 160	24	1.666	10	88.5	417
RHD40-110D12W	36 ~ 160	±12	±1.666	10	88	±833
RHD40-110D15W	36 ~ 160	±15	±1.333	10	89	±533

INPUT SPECIFICATIONS							
Parameter	Conditions		Min.	Typ.	Max.	Unit	
Operating input voltage range	110Vin(nom)		36	110	160	VDC	
Start up voltage	110Vin(nom)				36	VDC	
Shutdown voltage	110Vin(nom)		32	34	35.8	VDC	
Start up time	Constant resistive load	Power up		30	60	ms	
		Remote ON/OFF		30	60	ms	
Input surge voltage	1 second, max.	110Vin(nom)			200	VDC	
Input filter			Pi type				
Remote ON/OFF	Referred to -Vin pin	Positive logic (Standard)	DC-DC ON	Open or 3 ~ 12VDC			
		DC-DC OFF	Short or 0 ~ 1.2VDC				
		Negative logic (Option)	DC-DC ON	Short or 0 ~ 1.2VDC			
		DC-DC OFF	Open or 3 ~ 12VDC				
		Input current of Ctrl pin	-0.5		0.5	mA	
		Remote off input current		3		mA	

OUTPUT SPECIFICATIONS						
Parameter	Conditions		Min.	Typ.	Max.	Unit
Voltage accuracy			-1.0		+1.0	%
Line regulation	Low Line to High Line at Full Load	Single	-0.2		+0.2	%
		Dual	-0.5		+0.5	%
Load regulation	No Load to Full Load	Single	-0.5		+0.5	%
		Dual	-1.0		+1.0	%
Cross regulation	Asymmetrical load 25%/100% FL	Dual	-5.0		+5.0	%
Voltage adjustability	Single output	Other	-10		+10	%
Ripple and noise	Measured by 20MHz bandwidth With a 1μF/50V X7R MLCC	5Vout, 5.1Vout		75		
		12Vout, 15Vout		100		mVp-p
		24Vout		150		
Temperature coefficient			-0.02		+0.02	%/°C
Transient response recovery time	25% load step change			250		μs
Over voltage protection	Zener diode clamp	5Vout, 5.1Vout		6.2		
		12Vout		15		VDC
		15Vout		20		
		24Vout		30		
Over load protection	% of lout rated; Hiccup mode			150		%
Short circuit protection			Continuous, automatics recovery			

GENERAL SPECIFICATIONS

Parameter	Conditions	Min.	Typ.	Max.	Unit
Isolation voltage	1 minute (Reinforced insulation) Input to Output	3000			VAC
Isolation resistance	500VDC	1			GΩ
Isolation capacitance				1000	pF
Switching frequency		250	275	310	kHz
Safety approvals	IEC/ EN/ UL62368-1				UL:E193009 CB:UL(Demko)
Standard approvals	EN50155 EN45545-2				
Case material					Non-conductive black plastic
Base material					Non-conductive black plastic
Potting material					Silicone (UL94 V-0)
Weight					32g (1.13oz)
MTBF	MIL-HDBK-217F, Full load				1.253×10 ⁶ hrs

ENVIRONMENTAL SPECIFICATIONS

Parameter	Conditions	Min.	Typ.	Max.	Unit
Operating ambient temperature	With derating	-40		+105	°C
Maximum case temperature				105	°C
Over temperature protection					Internal temperature sensor
Storage temperature range		-55		+125	°C
Thermal impedance	Natural convection Without Heat-sink With Heat-sink		11.3 6.6		°C/W
Thermal shock					MIL-STD-810F
Shock					EN61373, MIL-STD-810F
Vibration					EN61373, MIL-STD-810F
Relative humidity					5% to 95% RH

EMC SPECIFICATIONS

Parameter	Conditions	Level
EMI	EN55032, EN50121-3-2 Without external component With external components	Class A Class B
EMS	EN55035, EN50121-3-2	
ESD	EN61000-4-2 Air ± 8kV and Contact ± 6kV	Perf. Criteria A
Radiated immunity	EN61000-4-3 20V/m	Perf. Criteria A
Fast transient	EN61000-4-4 ± 2kV	Perf. Criteria A
Surge	RHD40-110□□□W With 2 pcs of aluminum electrolytic capacitor (Nippon chemi-con KXJ series, 220μF/200V) and a TVS (SMDJ170A, 170V, 3000Watt peak pulse power) in parallel. EN61000-4-5 ± 2kV	Perf. Criteria A
Conducted immunity	EN61000-4-6 10Vr.m.s	Perf. Criteria A
Power frequency magnetic field	EN61000-4-8 100A/m continuous; 1000A/m 1 second	Perf. Criteria A

CHARACTERISTIC CURVE

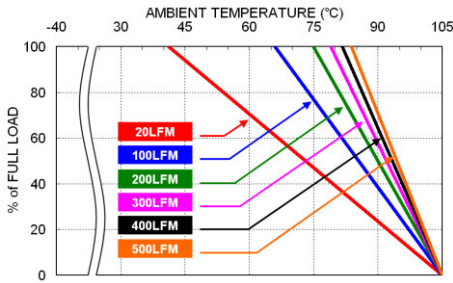

RHD40-110S05W Derating Curve

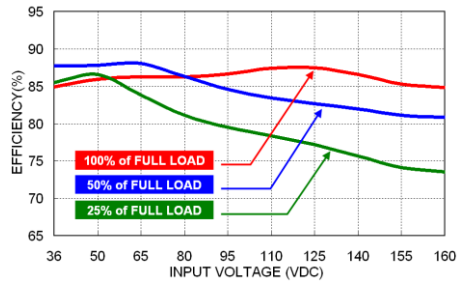

RHD40-110S05W Efficiency vs. Input Voltage

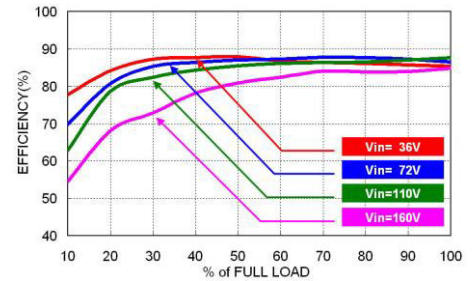

RHD40-110S05W Efficiency vs. Output Load

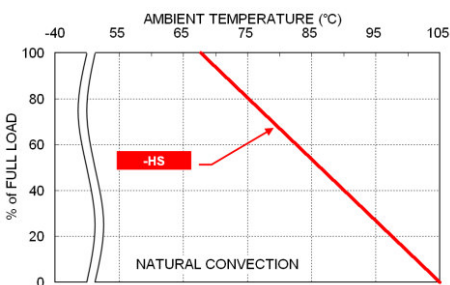

RHD40-110S05W Derating Curve With Heat-sink

FUSE CONSIDERATION

This power module is not internally fused. An input line fuse must always be used.

This encapsulated power module can be used in a wide variety of applications, ranging from simple stand-alone operation to an integrated part of sophisticated power architecture.

To maximum flexibility, internal fusing is not included; however, to achieve maximum safety and system protection, always use an input line fuse.

The input line fuse suggest as below :

Model	Fuse Rating (A)	Fuse Type
RHD40-110□□□W	3.15	Slow-Blow

The table based on the information provided in this data sheet on inrush energy and maximum DC input current at low Vin.

MECHANICAL DRAWING

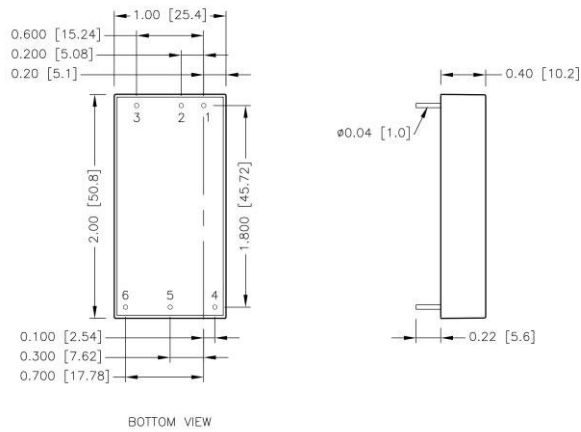

PIN CONNECTION

PIN	SINGLE	DUAL
1	+ Vin	+ Vin
2	- Vin	- Vin
3	Ctrl	Ctrl
4	+ Vout	+ Vout
5	- Vout	Com
6	Trim	- Vout

- All dimensions in inch [mm]
- Tolerance :x.xxx±0.02 [x.xx±0.5]
x.xxx±0.010 [x.xx±0.25]
- Pin dimension tolerance ±0.004[0.10]

-HS

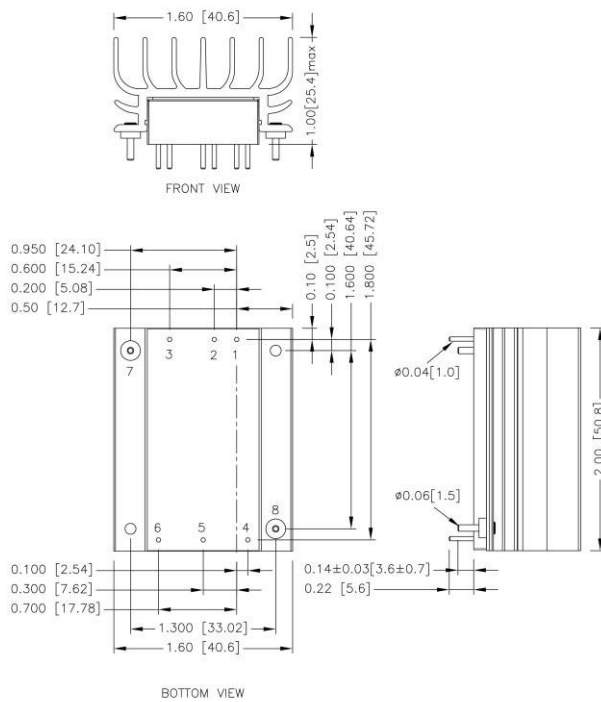

PIN CONNECTION

PIN	SINGLE	DUAL
1	+ Vin	+ Vin
2	- Vin	- Vin
3	Ctrl	Ctrl
4	+ Vout	+ Vout
5	- Vout	Com
6	Trim	- Vout
7	Heat-sink	Heat-sink
8	Heat-sink	Heat-sink

- All dimensions in inch [mm]
Tolerance :x.xxx±0.02 [x.xx±0.5]
x.xxx±0.010 [x.xx±0.25]
- Pin dimension tolerance ±0.004[0.10]

RECOMMENDED PAD LAYOUT

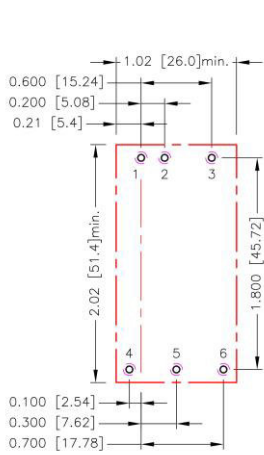

All dimensions in inch[mm]
 Pad size(lead free recommended)
 Through hole 1.2.3.4.5.6: $\Phi 0.051[1.30]$
 Top view pad 1.2.3.4.5.6: $\Phi 0.064[1.63]$
 Bottom view pad 1.2.3.4.5.6: $\Phi 0.102[2.60]$

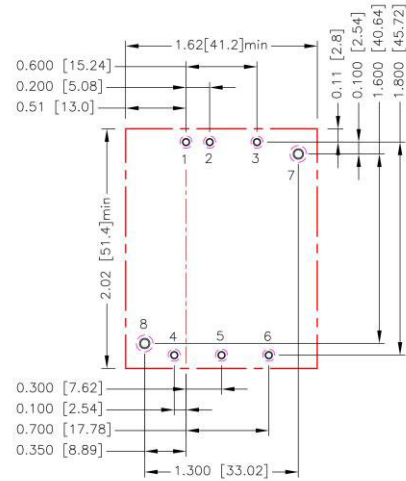

All dimensions in inch[mm]
 Pad size(lead free recommended)
 Through hole 1.2.3.4.5.6: $\Phi 0.051[1.30]$
 Through hole 7.8: $\Phi 0.071[1.80]$
 Top view pad 1.2.3.4.5.6: $\Phi 0.064[1.63]$
 Top view pad 7.8: $\Phi 0.089[2.25]$
 Bottom view pad 1.2.3.4.5.6: $\Phi 0.102[2.60]$
 Bottom view pad 7.8: $\Phi 0.142[3.60]$

THERMAL CONSIDERATIONS

The power module operates in a variety of thermal environments. However, sufficient cooling should be provided to help ensure reliable operation of the unit. Heat is removed by conduction, convection, and radiation to the surrounding environment. Proper cooling can be verified by measuring the point as the figure below. The temperature at this location should not exceed "Maximum case temperature". When operating, adequate cooling must be provided to maintain the test point temperature at or below "Maximum case temperature". You can limit this temperature to a lower value for extremely high reliability.

The unit will shutdown if the thermal reference point exceeds 115°C (typical), but the thermal shutdown is not intended as a guarantee that the unit will survive temperature beyond its rating. The module will automatically restarts after it cools down.

■ Thermal test condition with vertical direction by natural convection (20LFM).

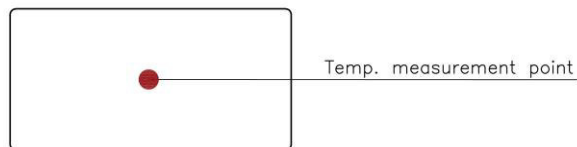

TOP VIEW

OUTPUT VOLTAGE ADJUSTMENT

It allows the user to increase or decrease the output voltage of the module.
 This is accomplished by connecting an external resistor between the Trim pin and either the +Vout or -Vout pins.
 With an external resistor between the Trim and -Vout pin, the output voltage increases.
 With an external resistor between the Trim and +Vout pin, the output voltage decreases.
 The external Trim resistor needs to be at least 1/8W of rated power.

EXTERNAL OUTPUT TRIMMING

Output can be externally trimmed by using the method shown below.

Trim-up

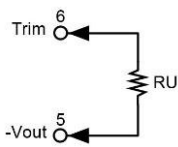

□□S05W										
ΔV (%)	1	2	3	4	5	6	7	8	9	10
Vout (V)	5.0500	5.1000	5.1500	5.2000	5.2500	5.3000	5.3500	5.4000	5.4500	5.5000
RU (k Ω)	35.360	16.244	9.752	6.483	4.514	3.198	2.257	1.550	1.000	0.559

□□S5P1W										
ΔV (%)	1	2	3	4	5	6	7	8	9	10
Vout (V)	5.151	5.202	5.253	5.304	5.355	5.406	5.457	5.508	5.559	5.610
RU (k Ω)	36.753	16.700	10.001	6.649	4.637	3.295	2.337	1.618	1.059	0.611

□□S12W										
ΔV (%)	1	2	3	4	5	6	7	8	9	10
Vout (V)	12.120	12.240	12.360	12.480	12.600	12.720	12.840	12.960	13.080	13.200
RU (k Ω)	392.864	172.175	101.446	66.591	45.837	32.068	22.264	14.929	9.234	4.685

□□S15W										
ΔV (%)	1	2	3	4	5	6	7	8	9	10
Vout (V)	15.150	15.300	15.450	15.600	15.750	15.900	16.050	16.200	16.350	16.500
RU (k Ω)	413.163	198.115	125.754	89.445	67.618	53.050	42.636	34.820	28.739	23.872

ΔV (%)	11	12	13	14	15	16	17	18	19	20
Vout (V)	16.650	16.800	16.950	17.100	17.250	17.400	17.550	17.700	17.850	18.000
RU (k Ω)	19.888	16.568	13.759	11.350	9.262	7.434	5.822	4.389	3.106	1.951

□□S24W										
ΔV (%)	1	2	3	4	5	6	7	8	9	10
Vout (V)	24.240	24.480	24.720	24.960	25.200	25.440	25.680	25.920	26.160	26.400
RU (k Ω)	947.146	472.772	303.499	216.605	163.724	128.153	102.589	83.329	68.298	56.240

ΔV (%)	11	12	13	14	15	16	17	18	19	20
Vout (V)	26.640	26.880	27.120	27.360	27.600	27.840	28.080	28.320	28.560	28.800
RU (k Ω)	46.353	38.099	31.104	25.101	19.892	15.330	11.302	7.718	4.509	1.619

OUTPUT VOLTAGE ADJUSTMENT(CONTINUED)

Trim-down

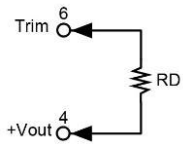
 S05W

ΔV (%)	1	2	3	4	5	6	7	8	9	10
Vout (V)	4.950	4.900	4.850	4.800	4.750	4.700	4.650	4.600	4.550	4.500
RD (k Ω)	46.686	20.817	12.360	8.162	5.653	3.984	2.794	1.903	1.210	0.656

 S5P1W

ΔV (%)	1	2	3	4	5	6	7	8	9	10
Vout (V)	5.049	4.998	4.947	4.8960	4.845	4.794	4.743	4.692	4.641	4.590
RD (k Ω)	47.801	21.688	13.003	8.663	6.061	4.326	3.088	2.159	1.436	0.859

 S12W

ΔV (%)	1	2	3	4	5	6	7	8	9	10
Vout (V)	11.880	11.760	11.640	11.520	11.400	11.280	11.160	11.040	10.920	10.800
RD (k Ω)	435.294	201.116	120.429	79.573	54.894	38.371	26.535	17.639	10.709	5.157

 S15W

ΔV (%)	1	2	3	4	5	6	7	8	9	10
Vout (V)	14.850	14.700	14.550	14.400	14.250	14.100	13.950	13.800	13.650	13.500
RD (k Ω)	302.154	132.978	78.547	51.685	35.680	25.055	17.489	11.826	7.429	3.916

 S24W

ΔV (%)	1	2	3	4	5	6	7	8	9	10
Vout (V)	23.760	23.520	23.280	23.040	22.800	22.560	22.320	22.080	21.840	21.600
RD (k Ω)	736.063	326.672	192.473	125.790	85.913	59.383	40.459	26.282	15.263	6.454