



P-DUKE POWER

TAD40 Multi Series

2 X 3.5 Inch AC-DC POWER SUPPLIES
Up to 40 Watts

3
YEARS
WARRANTY

ROHS
COMPLIANT

REACH
COMPLIANT



Automation



Datacom



IPC



Industry



Measurement



Telecom



Automobile



Boat



Charger



Medical



PV



Railway



3000
VAC
Isolation
Voltage

ADJ.
Output
Voltage

Internal
EN55032
Class **B**
Filter

LOW
Cross
Reg.

LOW
Leakage
Current

LOW
Standby
Power

Operating
Altitude
5000
meter

Protection
Class I
Class II

OPP

OVP

SCP

PART NUMBER STRUCTURE

TAD	40	U	□	□	□	□	□	C	- xx	yy	- □	□	□
Series Name	Output Power (W)	Input Voltage (VAC)	Output Quantity	Output Voltage 1 (VDC)	Output Voltage 2 (VDC)	Output Voltage 3 Polarity	Output Voltage 3 (VDC)	Protection Type	Vo2 Voltage Code	Vo3 Voltage Code	Connector Options	Application Options	Conformal Coating Options
				Vo1	Vo2	Vo3 (Triple only)							
A: Open type		U: Universal	D: Dual	3: 5	1: 2.5	M: Minus	1: 2.5	C: CLASS I			□: JST	□: None	□: None
U: U chassis type		85 ~ 264	T: Triple	4: 7.5	2: 3.3	□: Positive	2: 3.3	D: CLASS II			M: Molex	C: OVC III	R: Conformal
E: Enclosed type				5: 9	3: 5		3: 5				T: Terminal Block		Coating
D: Din rail type				6: 12	x: refer to		4: 7.5	□: CLASS I					
				7: 15	Suffix xx		5: 9	(※NRND)					
				8: 18			6: 12	B: CLASS II					
				9: 24			7: 15	(※NRND)					
				0: 28			8: 18						
							9: 24		※NRND: Not recommended for new designs				
							y: refer to						
							Suffix yy						



TECHNICAL SPECIFICATION All specifications are typical at 230VAC input, full load and 25°C unless otherwise noted

Model Number	Output 1			Output 2			Output 3		Max. Output Power W	Efficiency %	Maximum Capacitor Load μF
	Voltage	Current (Normal)	Current (MAX)	Voltage	Current (Normal)	Current (MAX)	Voltage	Current (MAX)			
	VDC	A	A	VDC	A	A	VDC	A			
TAD40UD32C TUD40UD32C TED40UD32C TDD40UD32C	+5	5	8	+3.3	4	6	---	---	40	89.5	12000 / 2000
TAD40UD63C TUD40UD63C TED40UD63C TDD40UD63C	+12	2.1	3.34	+5	4	6	---	---	40	89	1750 / 2000
TAD40UD62C TUD40UD62C TED40UD62C TDD40UD62C	+12	2.1	3.34	+3.3	4	6	---	---	40	90	1750 / 2000
TAD40UD73C TUD40UD73C TED40UD73C TDD40UD73C	+15	1.7	2.67	+5	4	6	---	---	40	88.5	1670 / 2000
TAD40UD93C TUD40UD93C TED40UD93C TDD40UD93C	+24	1.05	1.67	+5	4	6	---	---	40	86	440 / 2000
TAD40UD03C TUD40UD03C TED40UD03C TDD40UD03C	+28	0.72	1.43	+5	4	6	---	---	40	85.5	220 / 2000
TAD40UT32M3C TUD40UT32M3C TED40UT32M3C TDD40UT32M3C	+5	5	8	+3.3	4	6	-5	0.5	40	89	10000 / 2000 / 420
TAD40UT326C TUD40UT326C TED40UT326C TDD40UT326C	+5	5	8	+3.3	4	6	+12	0.5	40	89	10000 / 2000 / 420
TAD40UT32M6C TUD40UT32M6C TED40UT32M6C TDD40UT32M6C	+5	5	8	+3.3	4	6	-12	0.5	40	89	10000 / 2000 / 420
TAD40UT63M3C TUD40UT63M3C TED40UT63M3C TDD40UT63M3C	+12	2.1	3.34	+5	4	6	-5	0.5	40	88.5	1750 / 2000 / 420
TAD40UT63M6C TUD40UT63M6C TED40UT63M6C TDD40UT63M6C	+12	2.1	3.34	+5	4	6	-12	0.5	40	88	1750 / 2000 / 420



Model Number	Output 1			Output 2			Output 3		Max. Output Power W	Efficiency %	Maximum Capacitor Load μF
	Voltage	Current (Normal)	Current (MAX)	Voltage	Current (Normal)	Current (MAX)	Voltage	Current (MAX)			
	VDC	A	A	VDC	A	A	VDC	A			
TAD40UT623C TUD40UT623C TED40UT623C TDD40UT623C	+12	2.1	3.34	+3.3	4	6	+5	0.5	40	88.5	1750 / 2000 / 420
TAD40UT62M6C TUD40UT62M6C TED40UT62M6C TDD40UT62M6C	+12	2.1	3.34	+3.3	4	6	-12	0.5	40	88	1750 / 2000 / 420
TAD40UT73M7C TUD40UT73M7C TED40UT73M7C TDD40UT73M7C	+15	1.7	2.67	+5	4	6	-15	0.5	40	88	1670 / 2000 / 420
TAD40UT936C TUD40UT936C TED40UT936C TDD40UT936C	+24	1.05	1.67	+5	4	6	+12	0.5	40	86	440 / 2000 / 420
TAD40UT93M6C TUD40UT93M6C TED40UT93M6C TDD40UT93M6C	+24	1.05	1.67	+5	4	6	-12	0.5	40	86	440 / 2000 / 420

INPUT SPECIFICATIONS					
Parameter	Conditions	Min.	Typ.	Max.	Unit
Operating input voltage range	AC input	85		264	VAC
	DC input	120		370	VDC
Input frequency	AC input	47		63	Hz
Input current	100VAC			1.05	A
	240VAC			0.55	
No load input power	230VAC		0.15		Watts
Leakage current	264VAC		75		μA
Start up time				1000	ms
Rise time			20		ms
Hold up time	115VAC and Full Load		25		ms
Input inrush current	230VAC		60		A
Input protection	Internal fuse		T3.15A/250VAC		

OUTPUT SPECIFICATIONS						
Parameter	Conditions		Min.	Typ.	Max.	Unit
Output power	Pout 1+Pout 2+Pout 3				40	Watts
Initial set voltage accuracy	230VAC and Full Load	Vout 1 Vout 2 · Vout 3	-1.0 -2.0		+1.0 +2.0	%
Line regulation	Low Line to High Line at Full Load		-0.2		+0.2	%
Load regulation	No Load to Full Load		-0.5		+0.5	%
		Vout 1 Vout 3	-0.7		+0.7	
Cross regulation	No Load to Full Load		-1.5		+1.5	%
	0.1W Load to Full Load		-0.7		+0.7	
Cross regulation	Asymmetrical load 25%/100% FL		-1.5		+1.5	%
Voltage adjustability		Vout 1	-10		+10	%
Minimum load	T□D40UD□□ T□D40UT□□□□; Vout 3 is full load	Vout 1+Vout 2		0 0.5		W
Ripple and noise	Measured by 20MHz bandwidth					mVp-p
	With a 10µF/25V 1206 X7R MLCC	Vout 1 5V		100		
	With a 1µF/50V 1206 X7R MLCC	Vout 1 12V		120		
		15V		150		
		24V		240		
		28V		280		
	With a 10µF/25V 1206 X7R MLCC	Vout 2 All		100		
	With a 10µF/25V 1206 X7R MLCC	Vout 3 5V		100		
		12V		120		
		15V		150		
Temperature coefficient			-0.02		+0.02	%/°C
Transient response	Load step form 50 ~ 75% change at 2.5A/µs	Vout 1 Peak deviation Recovery time		600	3	%Vout µs
Over voltage protection	% of Vout(nom); Latch mode	Vout 1	125		140	%
Over power protection	% of nominal output power; Hiccup mode	Pout 1+Pout 2		145		%
Short circuit protection			Continuous, automatics recovery			

GENERAL SPECIFICATIONS						
Parameter	Conditions		Min.	Typ.	Max.	Unit
Isolation voltage	1 minute (Reinforced insulation)	Input to Output Input (Output) to F.G.	3000 2500			VAC
Isolation resistance	500VDC		0.1			GΩ
Switching frequency	230VAC	Vout 1 5V		70		kHz
		Others		115		
		Vout 2		750		
		Vout 3		510		
Safety approvals	IEC/ EN/ UL 62368-1					UL:E193009 CB:UL(Demko)
Weight	TAD					150 (5.29oz)
	TUD					198 (6.98oz)
	TED					216 (7.62oz)
	TDD					238 (8.40oz)
MTBF	MIL-HDBK-217F, Full load					1.716 x 10 ⁶ hrs

ENVIRONMENTAL SPECIFICATIONS						
Parameter	Conditions		Min.	Typ.	Max.	Unit
Operating ambient temperature	Natural convection	With derating	-40		+85	°C
Storage temperature range			-40		+85	°C
Operating altitude					5000	m
Shock						IEC60068-2-27
Vibration						IEC60068-2-6
Relative humidity	Non-condensing					5% to 95% RH

EMC SPECIFICATIONS

Parameter	Conditions		Level	
EMI	EN55032 and FCC Part 15		Conducted	Class B
	External components may be required for class I application.		Radiated	Class B
Harmonic currents	EN61000-3-2	Full Load	Class A	
Voltage flicker	EN61000-3-3			
EMS	EN55035 and Complies with EN 61850-3			
ESD	EN61000-4-2		Perf. Criteria A	
Radiated immunity	EN61000-4-3	20 V/m	Perf. Criteria A	
Fast transient	EN61000-4-4	± 4kV	Perf. Criteria A	
Surge	EN61000-4-5	DM ± 2kV and CM ± 4kV	Perf. Criteria A	
Conducted immunity	EN61000-4-6	20 Vr.m.s	Perf. Criteria A	
Power frequency magnetic field	EN61000-4-8	100 A/m	Perf. Criteria A	
Dip and interruptions	EN61000-4-11			
Damped oscillatory wave	EN61000-4-18	DM ± 1kV and CM ± 2.5kV	Perf. Criteria A	

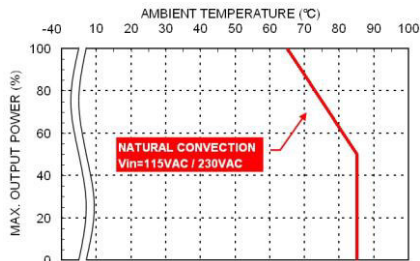
CHARACTERISTIC CURVE

TAD40UD Derating Curve vs. Ambient Temperature

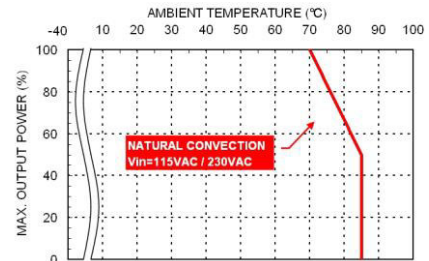

TAD40UT Derating Curve vs. Ambient Temperature

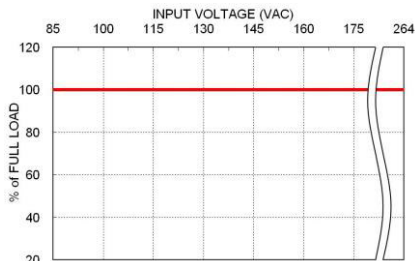

TAD40 Derating Curve vs. Input Voltage

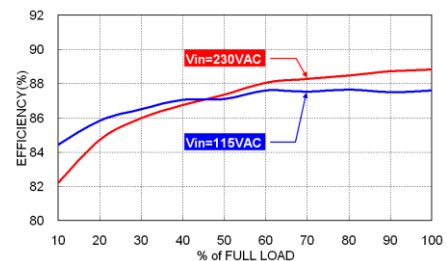

TAD40UT63M6B Efficiency vs. Output Load

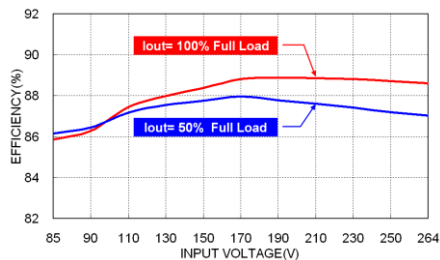

TAD40UT63M6B Efficiency vs. Input Voltage

MECHANICAL DRAWING

TAD Open type

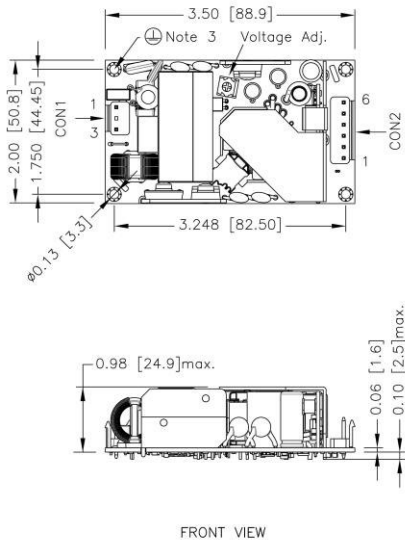

FRONT VIEW

TDD Din rail type

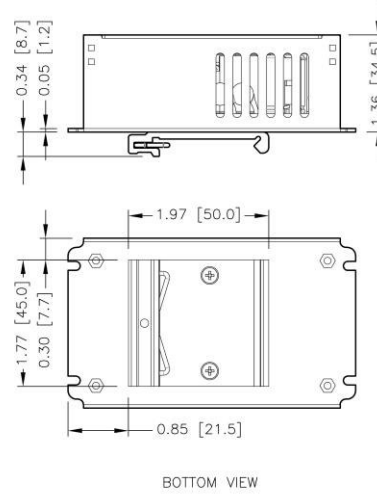

BOTTOM VIEW

1.All dimensions in inch[mm]

Tolerance: x.xx±0.02[x.x±0.5] x.xxx±0.010[x.xx±0.25]

2.The screw locked torque: MAX 5.0kgf-cm/0.49N-m

3.The screws holes can be considered as PE connection for CLASS I application.

1.All dimensions in inch[mm]

Tolerance: x.xx±0.02[x.x±0.5] x.xxx±0.010[x.xx±0.25]

2.The screw locked torque: MAX 5.0kgf-cm/0.49N-m

TED Enclosed type

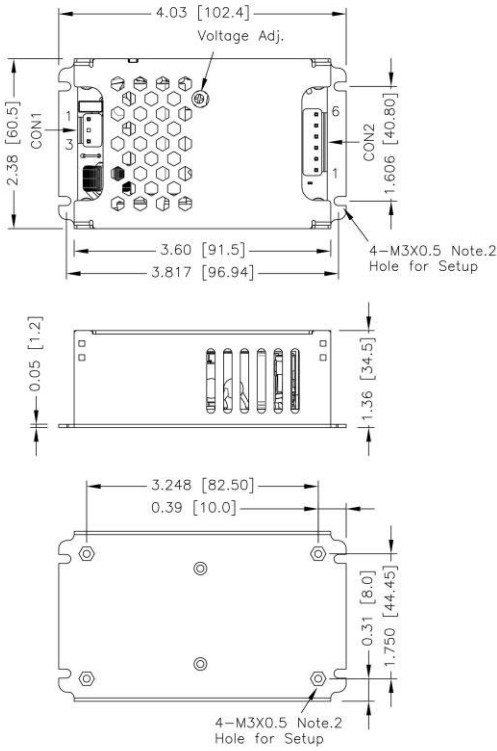

BOTTOM VIEW

TUD U chassis type

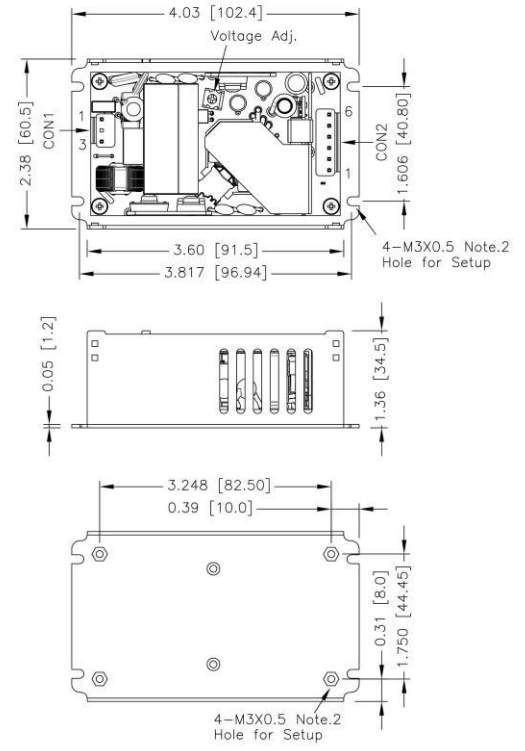

BOTTOM VIEW

1.All dimensions in inch[mm]

Tolerance: x.xx±0.02[x.x±0.5] x.xxx±0.010[x.xx±0.25]

2.The screw locked torque: MAX 5.0kgf-cm/0.49N-m

1.All dimensions in inch[mm]

Tolerance: x.xx±0.02[x.x±0.5] x.xxx±0.010[x.xx±0.25]

2.The screw locked torque: MAX 5.0kgf-cm/0.49N-m

CONNECTOR CONNECTIONS
CON1 – Input Connector

Pin Number	AC Input	DC Input
		T□D40UDXXC · T□D40UDXXD T□D40UTXXC · T□D40UTXXD
Pin 1	Line	DC+
Pin 3	Neutral	DC-

CON2 – Output Connector

Pin 1	Vout3
Pin 2,3	Com
Pin 4,5	Vout2
Pin 6	Vout1

*Either one of four screws holes of Chassis type can be considered as PE connection for CLASS I application.

CONNECTOR OPTIONS
Blank:
JST Type

Mates with housing

CON1: VHR-3N
CON2: VHR-6N

Crimp terminals

CON1: SVH-21T-P1.1
CON2: SVH-21T-P1.1
-M
Molex Type

Mates with housing

CON1: 09-50-8031
CON2: 09-50-8061

Crimp terminals

CON1: SD-2478
CON2: SD-2478
-T
Terminal Block
**Screw locked torque
MAX 2Kgf.cm/0.2N.m**

**Wire dimension range
26 ~ 16AWG**