



P-DUKE POWER

UFED40W Series

Chassis-Mount DC-DC Converter
Up to 40 Watts

3
YEARS
WARRANTY

ROHS
COMPLIANT

REACH
COMPLIANT



Railway



Automation



Datacom



IPC



Industry



Measurement



Telecom



Automobile



Boat



Charger



Medical



PV

CE UK
CA

3000 VDC Isolation Voltage	1600 VDC Isolation Voltage	4 : 1 Wide Input Range	FUSE Installed	INRUSH CURRENT LIMIT	LOW Standby Power	NO Min. Load Required	REMOTE ON OFF	REVERSE POLARITY PROTECTION	OCP	OTP	OVP
SCP	UVP										

PART NUMBER STRUCTURE

UFED40 -	48	S	05	W -	N	R	EC
Series Name	Input Voltage (VDC)	Output Quantity	Output Voltage (VDC)	Input Range	Remote Control Options	Conformal Coating Options	Assembly Options
	24:9.5~36 48:18~75 110:43~160	S:Single D: Dual	3P3:3.3 05:5 12:12 15:15 24:24 12:±12 15:±15 24:±24	4:1	□:Positive logic N:Negative logic	□: None R: Conformal Coating	□: None EC: Enclosed Mounting Type DR: Din Rail Mounting Type ED: Enclosed & Din Rail Mounting Type

TECHNICAL SPECIFICATION All specifications are typical at nominal input, full load and 25°C unless otherwise noted

Model Number	Input Range	Output Voltage	Output Current @Full Load	Input Current @No Load	Efficiency	Maximum Capacitor Load
	VDC	VDC	mA	mA	%	μF
UFED40-24S3P3W	9.5 ~ 36	3.3	10000	19	89	26600
UFED40-24S05W	9.5 ~ 36	5	8000	19	90	20000
UFED40-24S12W	9.5 ~ 36	12	3333	19	91	3900
UFED40-24S15W	9.5 ~ 36	15	2666	19	91	2600
UFED40-24S24W	9.5 ~ 36	24	1666	19	90	1300
UFED40-24D12W	9.5 ~ 36	±12	±1666	19	89	±2600
UFED40-24D15W	9.5 ~ 36	±15	±1333	19	89	±1600
UFED40-24D24W	9.5 ~ 36	±24	±833	19	90	±650
UFED40-48S3P3W	18 ~ 75	3.3	10000	14	89	26600
UFED40-48S05W	18 ~ 75	5	8000	14	90	20000
UFED40-48S12W	18 ~ 75	12	3333	14	91	3900
UFED40-48S15W	18 ~ 75	15	2666	14	91	2600
UFED40-48S24W	18 ~ 75	24	1666	14	90	1300
UFED40-48D12W	18 ~ 75	±12	±1666	14	89	±2600
UFED40-48D15W	18 ~ 75	±15	±1333	14	89	±1600
UFED40-48D24W	18 ~ 75	±24	±833	14	90	±650
UFED40-110S3P3W	43 ~ 160	3.3	10000	10	87	26600
UFED40-110S05W	43 ~ 160	5	8000	10	88	20000
UFED40-110S12W	43 ~ 160	12	3333	10	89.5	3900
UFED40-110S15W	43 ~ 160	15	2666	10	90	2600
UFED40-110S24W	43 ~ 160	24	1666	10	89	1300
UFED40-110D12W	43 ~ 160	±12	±1666	10	88	±2600
UFED40-110D15W	43 ~ 160	±15	±1333	10	88	±1600
UFED40-110D24W	43 ~ 160	±24	±833	10	90	±650

INPUT SPECIFICATIONS							
Parameter	Conditions		Min.	Typ.	Max.	Unit	
Operating input voltage range	24Vin(nom)		9.5	24	36	VDC	
	48Vin(nom)		18	48	75		
	110Vin(nom)		43	110	160		
Input fuse	slow blow	24Vin(nom)				8	A
		48Vin(nom)				4	
		110Vin(nom)				2	
In-rush current						15	A
Start up voltage	24Vin(nom)					9.5	VDC
	48Vin(nom)					18	
	110Vin(nom)					43	
Shutdown voltage	24Vin(nom)		7	8	9	VDC	
	48Vin(nom)		15	16	17.5		
	110Vin(nom)		37	40	42		
Start up time	Constant resistive load	Power up				100	ms
		Remote ON/OFF				60	
Input surge voltage	1 second, max.	24Vin(nom)				50	VDC
		48Vin(nom)				100	
		110Vin(nom)				170	
Remote ON/OFF	Referred to -Vin pin	Positive logic	DC-DC ON	Open or 3 ~ 12VDC			mA
		(Standard)	DC-DC OFF	Short or 0 ~ 1.2VDC			
		Negative logic	DC-DC ON	Short or 0 ~ 1.2VDC			
		(Option)	DC-DC OFF	Open or 3 ~ 12VDC			
		Input current of Ctrl pin				-0.5	mA
		Remote off input current				5	mA

OUTPUT SPECIFICATIONS						
Parameter	Conditions		Min.	Typ.	Max.	Unit
Voltage accuracy	3.3Vout		-1.5		+1.5	%
	Others		-1.0		+1.0	
Line regulation	Low Line to High Line at Full Load		-0.5		+0.5	%
Load regulation	No Load to Full Load		3.3Vout, 5Vout		+1.5	%
			Others		-1.0	
Cross regulation	Asymmetrical load 25%/100% FL		Dual		+5.0	%
Voltage adjustability	Single output		3.3Vout, 5Vout, 12Vout		+10	%
			15Vout, 24Vout		-10	
Ripple and noise	Measured by 20MHz bandwidth		3.3Vout, 5Vout,		75	mVp-p
			12Vout, 15Vout		100	
			24Vout		150	
Temperature coefficient			-0.02		+0.02	%/°C
Transient response recovery time	25% load step change				250	µs
Over voltage protection	Zener diode clamp		3.3Vout		3.9	VDC
			5Vout		6.2	
			12Vout		15	
			15Vout		20	
			24Vout		30	
Output indicator					Green LED	
Over load protection	% of Iout rated; Hiccup mode				150	%
Short circuit protection					Continuous, automatic recovery	

GENERAL SPECIFICATIONS						
Parameter	Conditions		Min.	Typ.	Max.	Unit
Isolation voltage	1 minute	110Vin(nom) Input to Output	3000			VDC
		Input (Output) to Chassis	1600			
		Others	Input to Output		1600	VDC
			Input (Output) to Chassis		1600	
Isolation resistance	500VDC				1	GΩ
Isolation capacitance					4000	pF
Switching frequency			225	250	275	kHz
Safety meets					IEC/ EN/ UL62368-1	
Standard approvals					EN50155 EN45545-2	
Chassis material					Aluminum	
Conformal coating					Impregnating varnish	
Weight					110g (3.88oz)	
MTBF	MIL-HDBK-217F, Full load				1.944 x 10 ⁶ hrs	

ENVIRONMENTAL SPECIFICATIONS						
Parameter	Conditions		Min.	Typ.	Max.	Unit
Operating ambient temperature	with derating		-40		+105	°C
Over temperature protection	Case of DC/DC module				115	°C
Storage temperature range			-40		+105	°C
Thermal shock					MIL-STD-810F	
Shock					EN61373, MIL-STD-810F	
					EN61373, MIL-STD-810F	
					EN61373, IEC60068-2-27	
					EN61373, IEC60068-2-27	
Vibration					EN61373, MIL-STD-810F	
					EN61373, MIL-STD-810F	
					EN61373, IEC60068-2-6	
					EN61373, IEC60068-2-6	
Relative humidity					5% to 95% RH	

EMC SPECIFICATIONS

Parameter	Conditions		Level
EMI	EN55032, EN50121-3-2		Class B
EMS	EN55035, EN50121-3-2		
ESD	EN61000-4-2	Air $\pm 8kV$ and Contact $\pm 6kV$	Perf. Criteria A
Radiated immunity	EN61000-4-3	20V/m	Perf. Criteria A
Fast transient	EN61000-4-4	$\pm 2kV$	Perf. Criteria A
Surge	EN61000-4-5	EN55035 $\pm 1kV$ and EN50121-3-2 $\pm 2kV$	Perf. Criteria A
Conducted immunity	EN61000-4-6	10Vr.m.s	Perf. Criteria A
Power frequency magnetic field	EN61000-4-8	100A/m continuous; 1000A/m 1 second	Perf. Criteria A

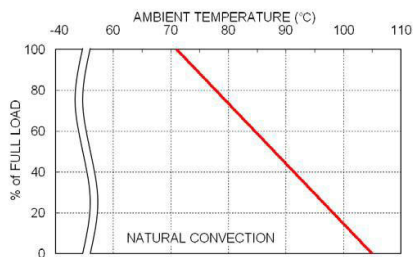
CHARACTERISTIC CURVE

UFED40-48S05W Derating Curve

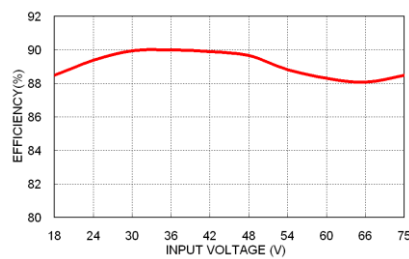

UFED40-48S05W Efficiency vs. Input Voltage

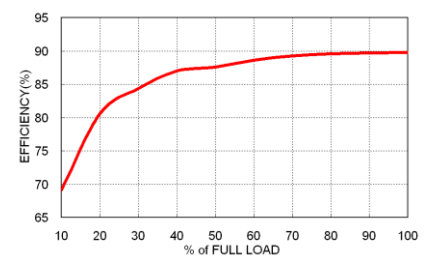

UFED40-48S05W Efficiency vs. Output Load

MECHANICAL DRAWING

CHASSIS MOUNTING TYPE

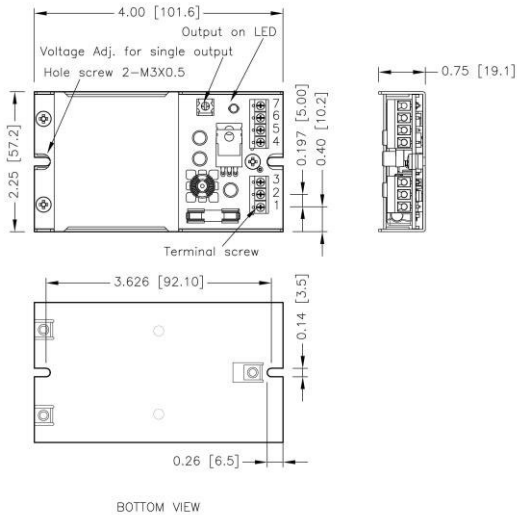

TERMINAL CONNECTION

NO.	SINGLE	DUAL
1	+Vin	+Vin
2	-Vin	-Vin
3	Ctrl	Ctrl
4	NC	NC
5	-Vout	-Vout
6	+Vout	Common
7	NC	+Vout

- ※ NC : No Connection
- ※ Screw terminals – wire range from 14 to 18 AWG

1. All dimensions in Inch [mm]
2. Tolerance : X.XX±0.02 [X.X±0.5]
X.XXX±0.01 [X.XX±0.25]
3. Hole screw locked torque :
MAX 5.0kgf-cm/ 0.49N-m
4. Terminal screw locked torque :
MAX 2.5kgf-cm/ 0.25N-m

ENCLOSED MOUNTING TYPE

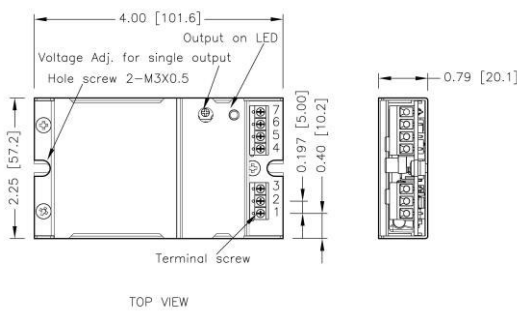

DIN RAIL MOUNTING TYPE

