



P-DUKE POWER

URED20W Series

Chassis-Mount DC-DC Converter
Up to 20 Watts

3
YEARS
WARRANTY

ROHS
COMPLIANT

REACH
COMPLIANT



Railway



Automation



Datacom



IPC



Industry



Measurement



Telecom



Automobile



Boat



Charger



Medical



PV

CE UK
CA

2250
VDC
Isolation
Voltage

4 : 1
Wide
Input
Range

FUSE
Installed

INRUSH
CURRENT
LIMIT

LOW
Standby
Power

NO
Min. Load
Required

REMOTE
ON
OFF

REVERSE
POLARITY
PROTECTION

OCP

OVP

SCP

UVP

PART NUMBER STRUCTURE

URED20 -	48	S	05	W -	N	R	EC
Series Name	Input Voltage (VDC)	Output Quantity	Output Voltage (VDC)	Input Range	Remote Control Options	Conformal Coating Options	Assembly Options
	24:9~36 48:18~75 110:43~160	S:Single D: Dual	3P3:3.3 05:5 12:12 15:15 12:±12 15:±15	4:1	□:Positive logic N:Negative logic	□: None R: Conformal Coating	□: None EC: Enclosed Mounting Type DR: Din Rail Mounting Type ED: Enclosed & Din Rail Mounting Type

TECHNICAL SPECIFICATION All specifications are typical at nominal input, full load and 25°C unless otherwise noted

Model Number	Input Range	Output Voltage	Output Current @Full Load	Input Current @No Load	Efficiency	Maximum Capacitor Load
	VDC	VDC	mA	mA	%	μF
URED20-24S3P3W	9 ~ 36	3.3	4500	8	84	7000
URED20-24S05W	9 ~ 36	5	4000	8	87	5000
URED20-24S12W	9 ~ 36	12	1670	8	88	850
URED20-24S15W	9 ~ 36	15	1330	8	87	700
URED20-24D12W	9 ~ 36	±12	±833	8	87	±500
URED20-24D15W	9 ~ 36	±15	±667	8	88	±350
URED20-48S3P3W	18 ~ 75	3.3	4500	6	84	7000
URED20-48S05W	18 ~ 75	5	4000	6	87	5000
URED20-48S12W	18 ~ 75	12	1670	6	88	850
URED20-48S15W	18 ~ 75	15	1330	6	88	700
URED20-48D12W	18 ~ 75	±12	±833	6	87	±500
URED20-48D15W	18 ~ 75	±15	±667	6	88	±350
URED20-110S3P3W	43 ~ 160	3.3	4500	5	84	7000
URED20-110S05W	43 ~ 160	5	4000	5	86	5000
URED20-110S12W	43 ~ 160	12	1670	5	87	850
URED20-110S15W	43 ~ 160	15	1330	5	87	700
URED20-110D12W	43 ~ 160	±12	±833	5	87	±500
URED20-110D15W	43 ~ 160	±15	±667	5	88	±350

INPUT SPECIFICATIONS						
Parameter	Conditions		Min.	Typ.	Max.	Unit
Operating input voltage range	24Vin(nom)		9	24	36	VDC
	48Vin(nom)		18	48	75	
	110Vin(nom)		43	110	160	
Input fuse	slow blow	24Vin(nom)				6
		48Vin(nom)				4
		110Vin(nom)				2
In-rush current						15
Start up voltage	24Vin(nom)					9
	48Vin(nom)					18
	110Vin(nom)					43
Shutdown voltage	24Vin(nom)		7.5	8	8.8	VDC
	48Vin(nom)		15.5	16	17.5	
	110Vin(nom)		38.5	40	42	
Start up time	Constant resistive load	Power up				100
		Remote ON/OFF				30
Input surge voltage	1 second, max.	24Vin(nom)				50
		48Vin(nom)				100
		110Vin(nom)				170
Remote ON/OFF	Referred to -Vin pin	Positive logic	DC-DC ON	Open or 3 ~ 15VDC		
		(Standard)	DC-DC OFF	Short or 0 ~ 1.2VDC		
		Negative logic	DC-DC ON	Short or 0 ~ 1.2VDC		
		(Option)	DC-DC OFF	Open or 3 ~ 15VDC		
		Input current of Ctrl pin		-0.5		
Remote off input current					5	

OUTPUT SPECIFICATIONS						
Parameter	Conditions		Min.	Typ.	Max.	Unit
Voltage accuracy	3.3Vout		-1.5		+1.5	%
	Others		-1.0		+1.0	
Line regulation	Low Line to High Line at Full Load		Single		+0.2	%
			Dual		+0.5	
Load regulation	No Load to Full Load		3.3Vout		+1.5	%
			Others		+1.0	
Cross regulation	Asymmetrical load 25%/100% FL	Dual	-5.0		+5.0	%
Voltage adjustability	Single output		-10		+10	%
Ripple and noise	Measured by 20MHz bandwidth			75		mVp-p
Temperature coefficient			-0.02		+0.02	%/°C
Transient response recovery time	25% load step change			250		µs
Over voltage protection	3.3Vout		3.7		5.4	VDC
	5Vout		5.6		7.0	
	12Vout		13.5		19.6	
	15Vout		16.8		20.5	
Output indicator				Green LED		
Over load protection	% of Iout rated			150		%
Short circuit protection			Continuous, automatic recovery			

GENERAL SPECIFICATIONS						
Parameter	Conditions		Min.	Typ.	Max.	Unit
Isolation voltage	1 minute	Input to Output Input (Output) to Chassis	2250 1600			VDC
Isolation resistance	500VDC		1			GΩ
Isolation capacitance				5000		pF
Switching frequency			297	330	363	kHz
Safety meets			IEC/ EN/ UL62368-1			
Standard approvals			EN50155 EN45545-2			
Chassis material			Aluminum			
Conformal coating			Impregnating varnish			
Weight			105g (3.70oz)			
MTBF	MIL-HDBK-217F, Full load		1.338 x 10 ⁶ hrs			

ENVIRONMENTAL SPECIFICATIONS						
Parameter	Conditions		Min.	Typ.	Max.	Unit
Operating ambient temperature	With derating		-40		+105	°C
Storage temperature range			-40		+105	°C
Thermal shock			MIL-STD-810F			
Shock	□□S□□W-□□		EN61373, MIL-STD-810F			
	□□S□□W-□□EC		EN61373, MIL-STD-810F			
	□□S□□W-□□DR		EN61373, IEC60068-2-27			
	□□S□□W-□□ED		EN61373, IEC60068-2-27			
Vibration	□□S□□W-□□		EN61373, MIL-STD-810F			
	□□S□□W-□□EC		EN61373, MIL-STD-810F			
	□□S□□W-□□DR		EN61373, IEC60068-2-6			
	□□S□□W-□□ED		EN61373, IEC60068-2-6			
Relative humidity			5% to 95% RH			

EMC SPECIFICATIONS

Parameter	Conditions		Level
EMI	EN55032, EN50121-3-2		Class B
EMS	EN55035, EN50121-3-2		
ESD	EN61000-4-2	Air $\pm 8\text{kV}$ and Contact $\pm 6\text{kV}$	Perf. Criteria A
Radiated immunity	EN61000-4-3	20V/m	Perf. Criteria A
Fast transient	EN61000-4-4	$\pm 2\text{kV}$	Perf. Criteria A
Surge	EN61000-4-5	EN55035 $\pm 1\text{kV}$ and EN50121-3-2 $\pm 2\text{kV}$	Perf. Criteria A
Conducted immunity	EN61000-4-6	10Vr.m.s	Perf. Criteria A
Power frequency magnetic field	EN61000-4-8	100A/m continuous; 1000A/m 1 second	Perf. Criteria A

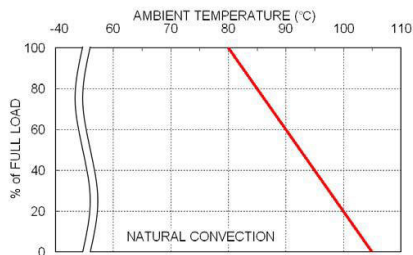
CHARACTERISTIC CURVE

URED20-48S05W Derating Curve

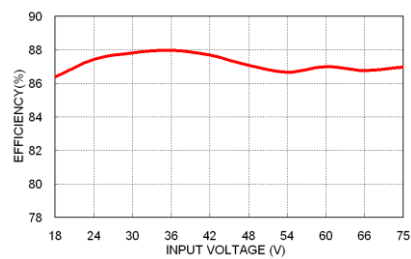

URED20-48S05W Efficiency vs. Input Voltage

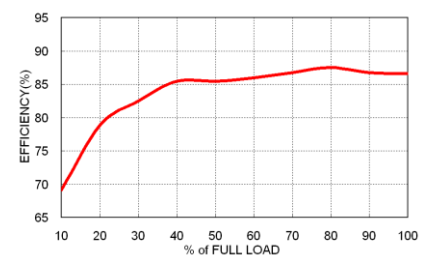

URED20-48S05W Efficiency vs. Output Load

MECHANICAL DRAWING

CHASSIS MOUNTING TYPE

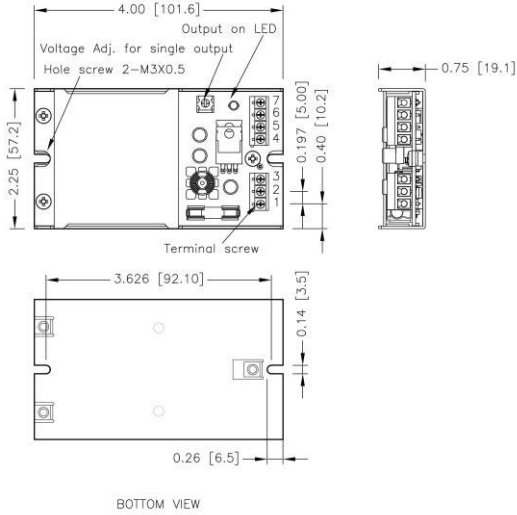

TERMINAL CONNECTION

NO.	SINGLE	DUAL
1	+Vin	+Vin
2	-Vin	-Vin
3	Ctrl	Ctrl
4	NC	NC
5	-Vout	-Vout
6	+Vout	Common
7	NC	+Vout

- ※ NC : No Connection
- ※ Screw terminals – wire range from 14 to 18 AWG

1. All dimensions in Inch [mm]
2. Tolerance : X.XX±0.02 [X.X±0.5]
X.XXX±0.01 [X.XX±0.25]
3. Hole screw locked torque :
MAX 5.0kgf-cm/0.49N-m
4. Terminal screw locked torque :
MAX 2.5kgf-cm/0.25N-m

ENCLOSED MOUNTING TYPE

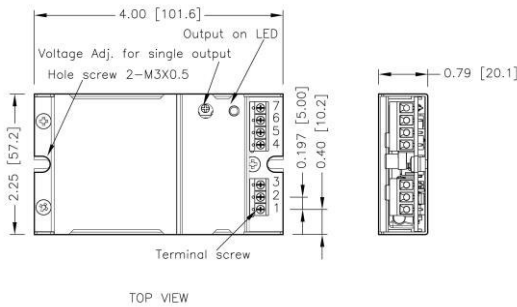

DIN RAIL MOUNTING TYPE

